

**HARSCO**  
INDUSTRIAL  
Patterson-Kelley  
East Stroudsburg, PA 18301  
570-476-7261  
www.harscopk.com

IF ANY OF THE ORIGINAL WIRE SUPPLIED WITH THIS BOILER MUST BE REPLACED, IT MUST BE REPLACED WITH THE SAME UL WIRE TYPE.

SC3000 - SC4000 / 480 VOLT  
NURO™ Control

2660000341 (1)  
REV. F

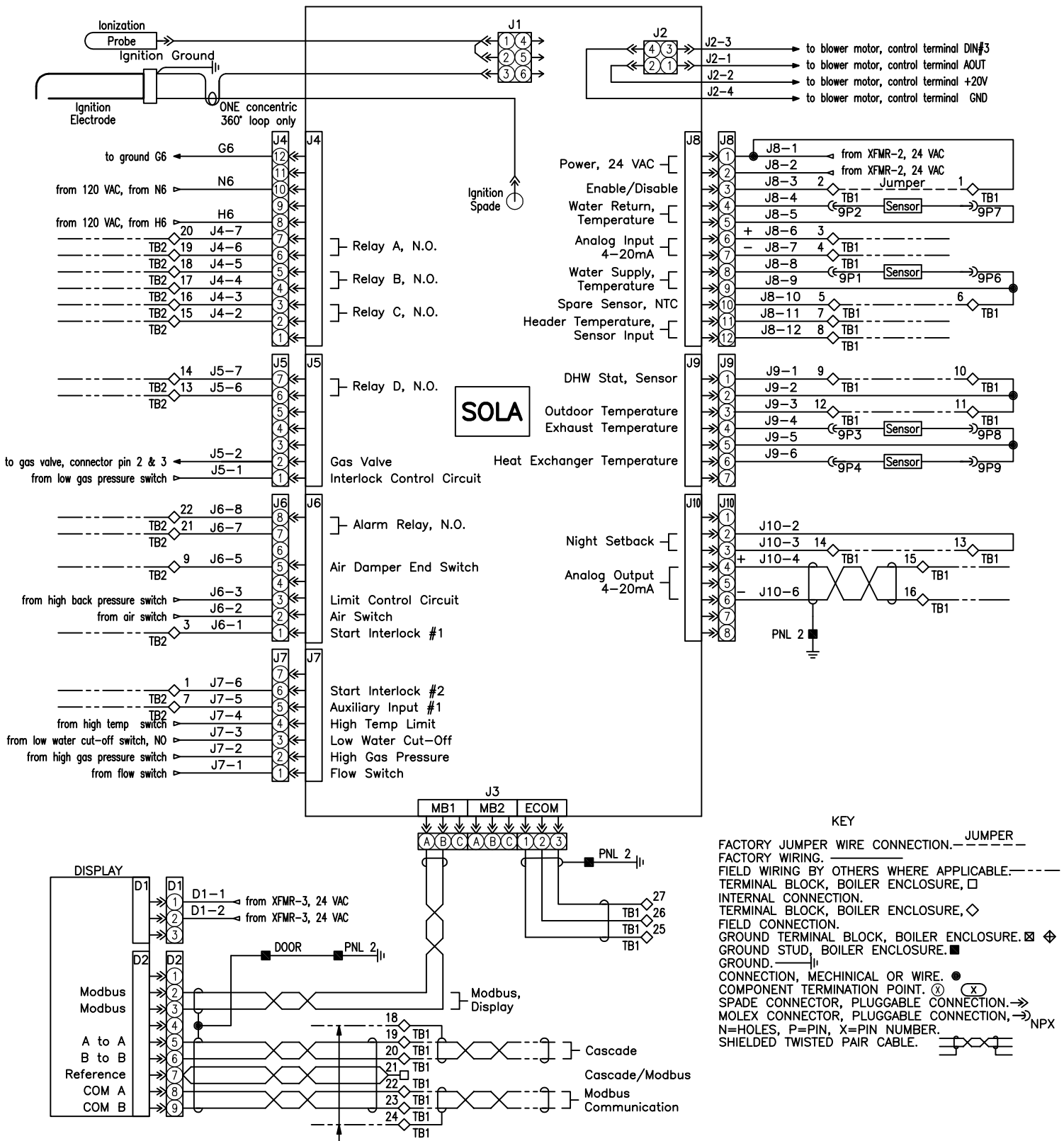

**NOTE:** Modbus and or Cascade field wiring must utilize twisted pair shielded cable. For multi boiler installations, JUMPER the field Modbus and or Cascade shield connection " TB1-18 and or TB1-24" to PNL ground in Master boiler TB1 terminal box. Do not ground shield to any other boiler or piece of equipment. Shield should be continuous from beginning to end with a ground connection in the master boiler only.

**HARSCO**  
**INDUSTRIAL**  
Patterson-Kelley  
East Stroudsburg, PA 18301  
570-476-7261  
www.harscopk.com

IF ANY OF THE ORIGINAL WIRE SUPPLIED WITH THIS BOILER MUST BE REPLACED, IT MUST BE REPLACED WITH THE SAME UL WIRE TYPE.

SC3000 - SC4000 / 480 VOLT  
NURO™ Control

2660000341 (2)  
REV. F