

HARSCO

INDUSTRIAL

Patterson-Kelley

East Stroudsburg, PA 18301
570-476-7261
www.harscopk.com

IF ANY OF THE ORIGINAL WIRE SUPPLIED WITH THIS BOILER MUST BE REPLACED, IT MUST BE REPLACED WITH THE SAME UL WIRE TYPE.

SC3000 - SC4000 / 240 VOLT
NURO™ Control

2660000342 (1)
REV. F

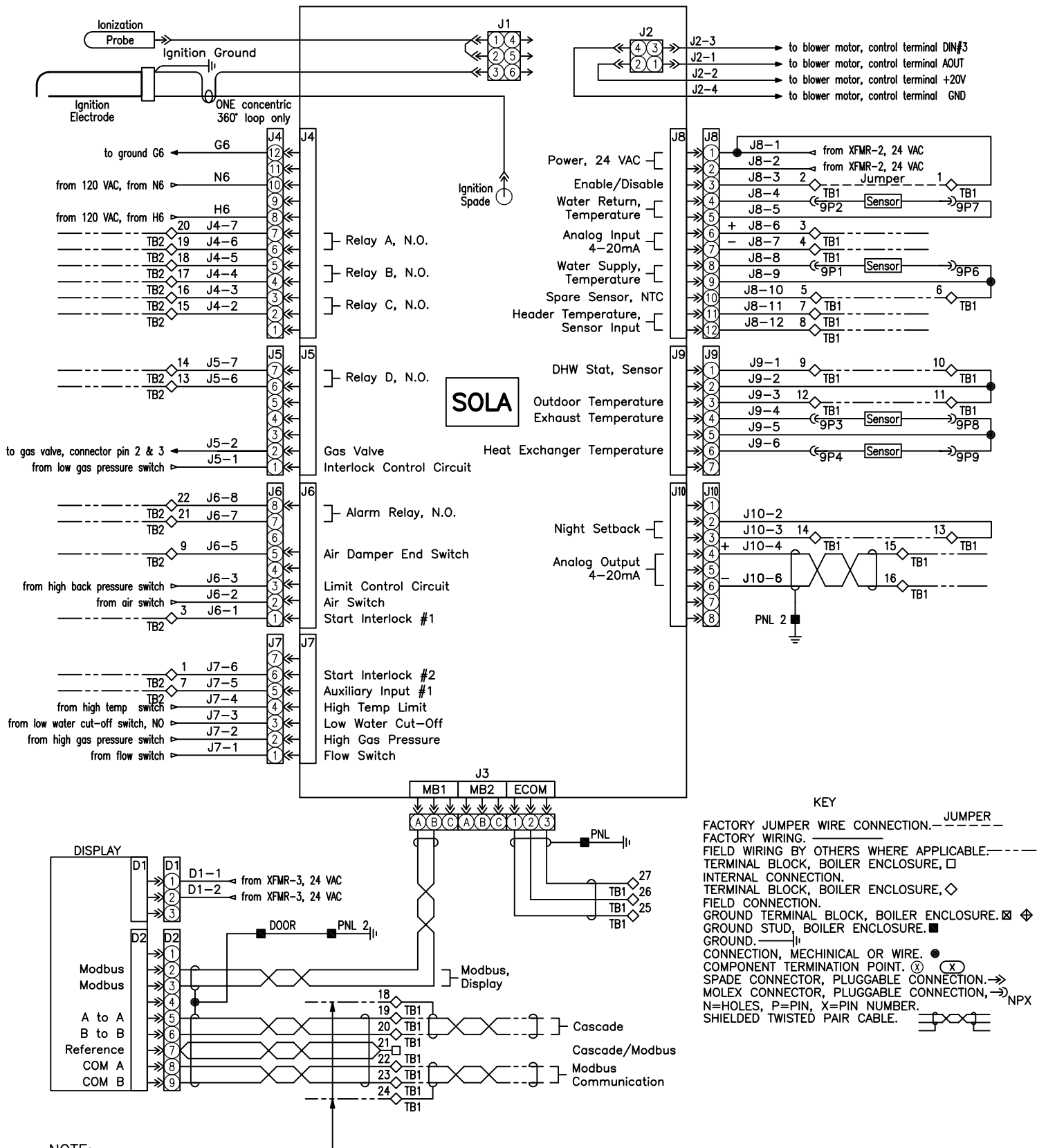

NOTE:

Modbus and or Cascade field wiring must utilize twisted pair shielded cable. For multi boiler installations, JUMPER the field Modbus and or Cascade shield connection "TB1-18 and or TB1-24" to PNL ground in Master boiler TB1 terminal box. Do not ground shield to any other boiler or piece of equipment. Shield should be continuous from beginning to end with a ground connection in the master boiler only.

HARSCO
INDUSTRIAL

Patterson-Kelley
East Stroudsburg, PA 18301
570-476-7261
www.harscopk.com

IF ANY OF THE ORIGINAL WIRE SUPPLIED WITH THIS BOILER MUST BE REPLACED, IT MUST BE REPLACED WITH THE SAME UL WIRE TYPE.

SC3000 - SC4000 / 240 VOLT
NURO™ Control

2660000342 (2)
REV. F