

SUPPLY BY OTHERS,  
BRANCH CIRCUIT, 20 AMPS  
120 VAC 1Ø 60 HZ

FUSE FU1 IS BUSSMAN  
15A FNQ-R SERIES CLASS CC ONLY

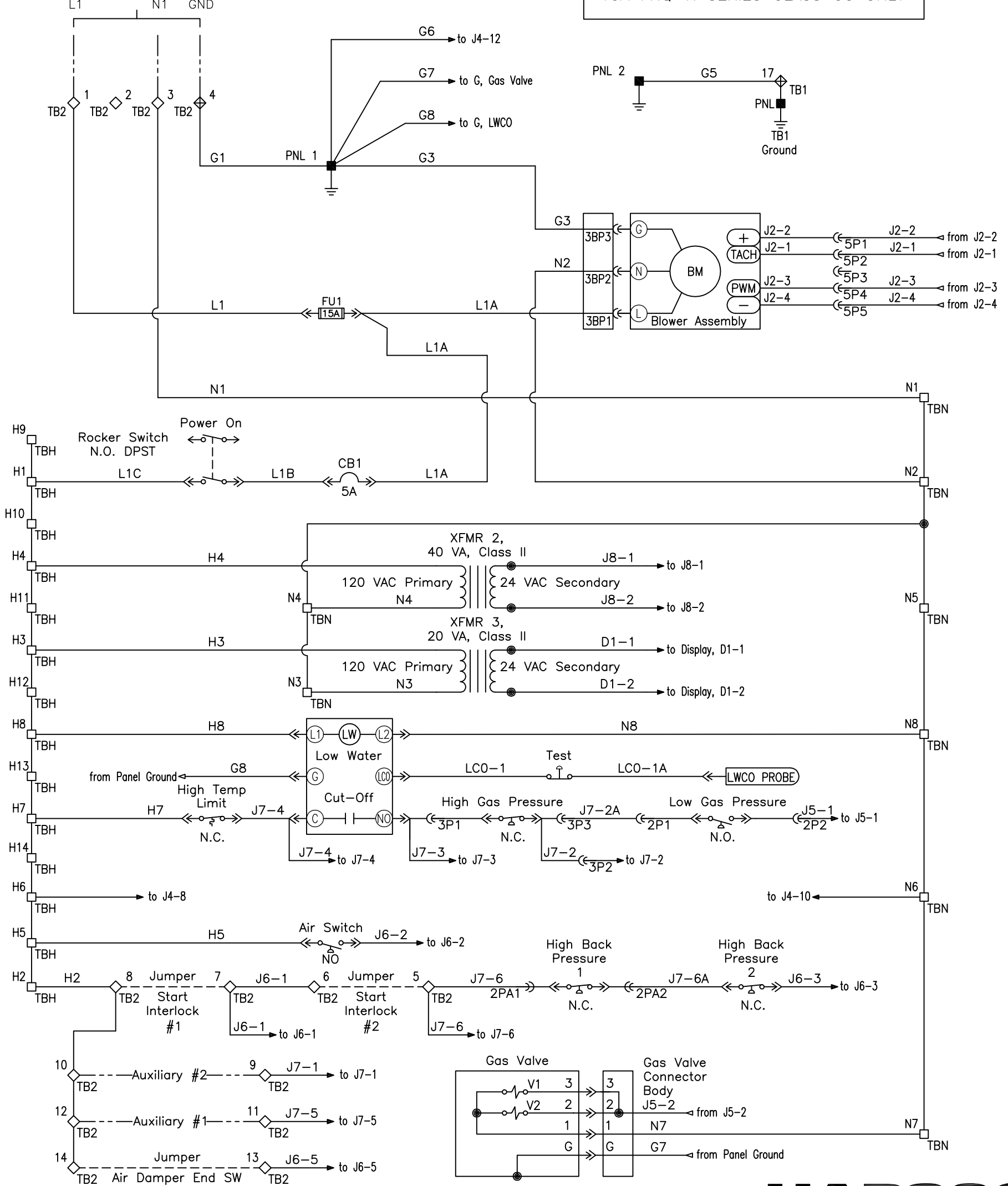

**HARSCO**  
INDUSTRIAL  
Patterson-Kelley  
East Stroudsburg, PA 18301  
570-476-7261  
www.harscopk.com

IF ANY OF THE ORIGINAL WIRE SUPPLIED WITH THIS BOILER MUST BE REPLACED, IT MUST BE REPLACED WITH THE SAME UL WIRE TYPE.

C2500 / 120 VOLT  
NURO™ Control

264100041 (1)  
REV. B

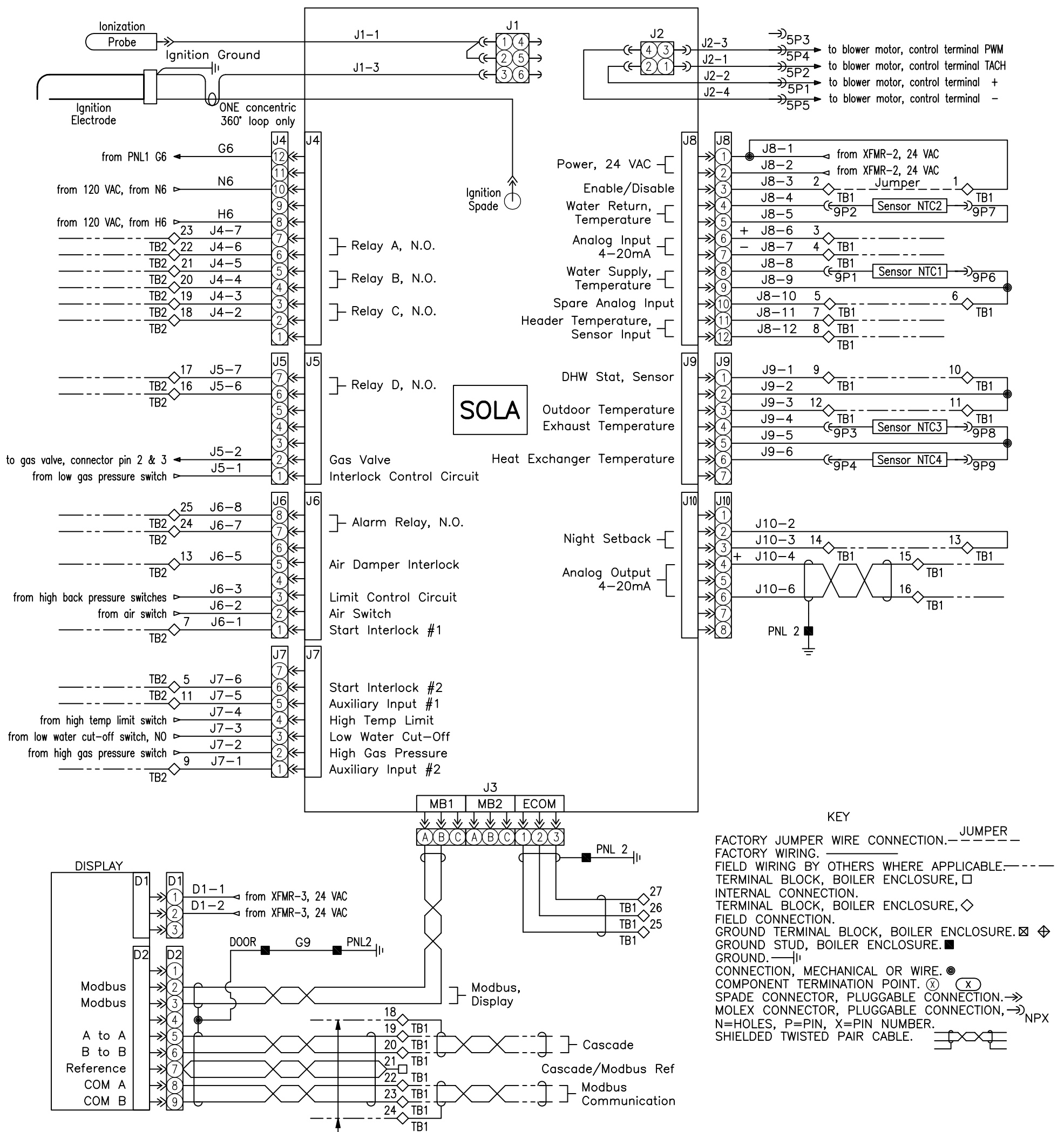

NOTE: Modbus and or Cascade field wiring must utilize twisted pair shielded cable. For multi boiler installations, JUMPER the field Modbus and or Cascade shield connection "TB1-18 and or TB1-24" to PNL ground in Master boiler TB1 terminal box. Do not ground shield to any other boiler or piece of equipment. Shield should be continuous from beginning to end with a ground connection in the master boiler only.

**HARSCO**  
INDUSTRIAL  
Patterson-Kelley  
East Stroudsburg, PA 18301  
570-476-7261  
www.harscopk.com

IF ANY OF THE ORIGINAL WIRE SUPPLIED WITH THIS BOILER MUST BE REPLACED, IT MUST BE REPLACED WITH THE SAME UL WIRE TYPE.

**C2500 / 120 VOLT**  
**NURO™ Control**

**264100041 (2)**  
**REV. B**