

HARSCO
INDUSTRIAL
Patterson-Kelley
East Stroudsburg, PA 18301
570-476-7261
www.harscopk.com

IF ANY OF THE ORIGINAL WIRE SUPPLIED WITH THIS BOILER MUST BE REPLACED, IT MUST BE REPLACED WITH THE SAME UL WIRE TYPE.

C3000 - C4000 / 240 VOLT
NURO™ Control

2641000042 (1)
REV. B

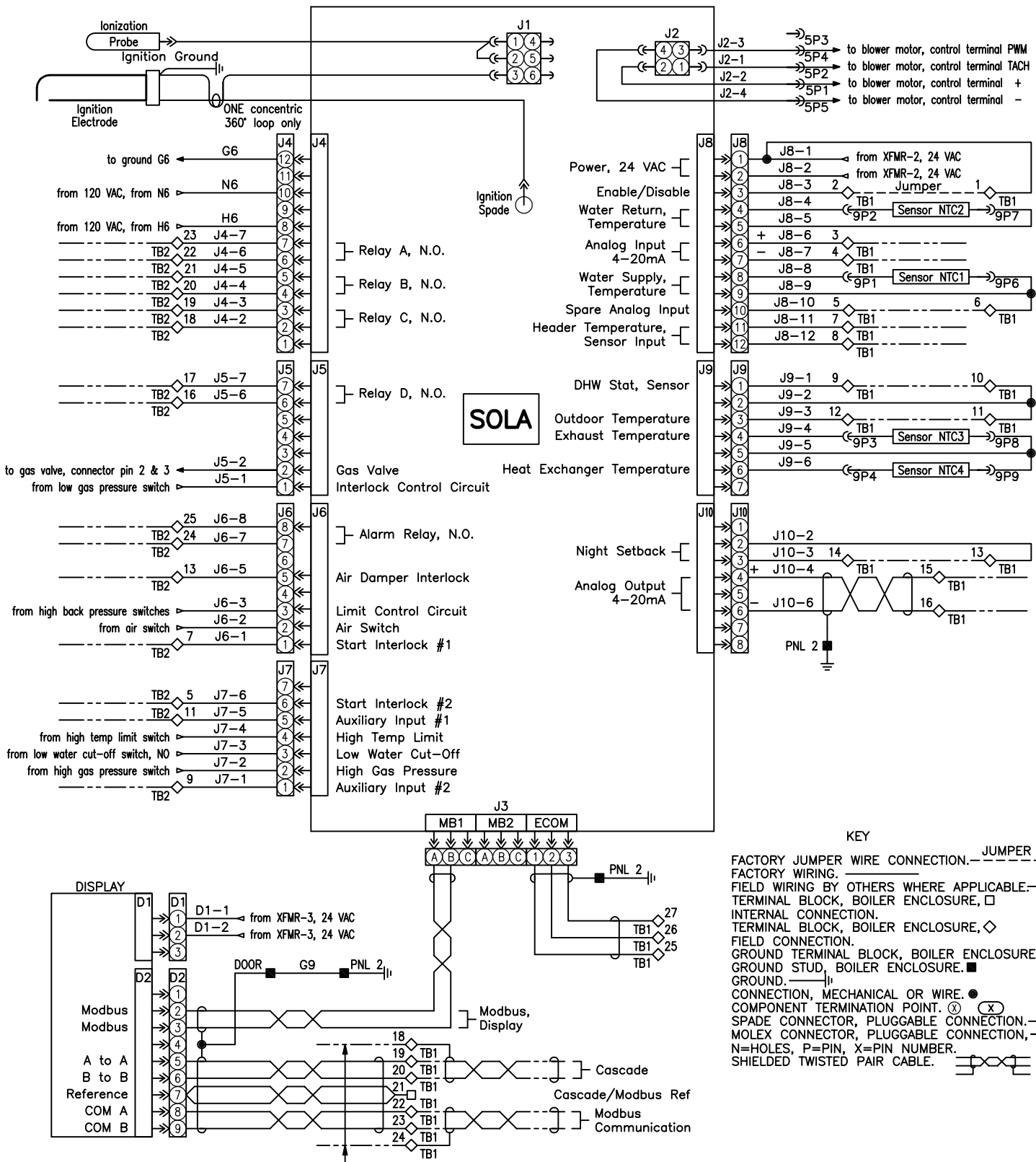

SOLA

KEY

FACTORY JUMPER WIRE CONNECTION. — JUMPER —
 FACTORY WIRING. —
 FIELD WIRING BY OTHERS WHERE APPLICABLE. - - - -
 TERMINAL BLOCK, BOILER ENCLOSURE, □
 INTERNAL CONNECTION.
 TERMINAL BLOCK, BOILER ENCLOSURE, ◇
 FIELD CONNECTION.
 GROUND TERMINAL BLOCK, BOILER ENCLOSURE. ⊠ ⊠
 GROUND STUD, BOILER ENCLOSURE. ■
 GROUND. —||—
 CONNECTION, MECHANICAL OR WIRE. ●
 COMPONENT TERMINATION POINT. ⊗ (X)
 SPADE CONNECTOR, PLUGGABLE CONNECTION. →
 MOLEX CONNECTOR, PLUGGABLE CONNECTION. → NPX
 N=HOLES, P=PIN, X=PIN NUMBER.
 SHIELDED TWISTED PAIR CABLE. —||—

NOTE: Modbus and or Cascade field wiring must utilize twisted pair shielded cable. For multi boiler installations, JUMPER the field Modbus and or Cascade shield connection " TB1-18 and or TB1-24" to PNL ground in Master boiler TB1 terminal box. Do not ground shield to any other boiler or piece of equipment. Shield should be continuous from beginning to end with a ground connection in the master boiler only.

HARSCO
INDUSTRIAL
Patterson-Kelley
 East Stroudsburg, PA 18301
 570-476-7261
 www.harscopk.com