

SUPPLY BY OTHERS,
BRANCH CIRCUIT, 20 AMPS
120 VAC 1Ø 60 HZ

FUSE FU1 IS BUSSMAN
5A FNQ-R SERIES CLASS CC ONLY

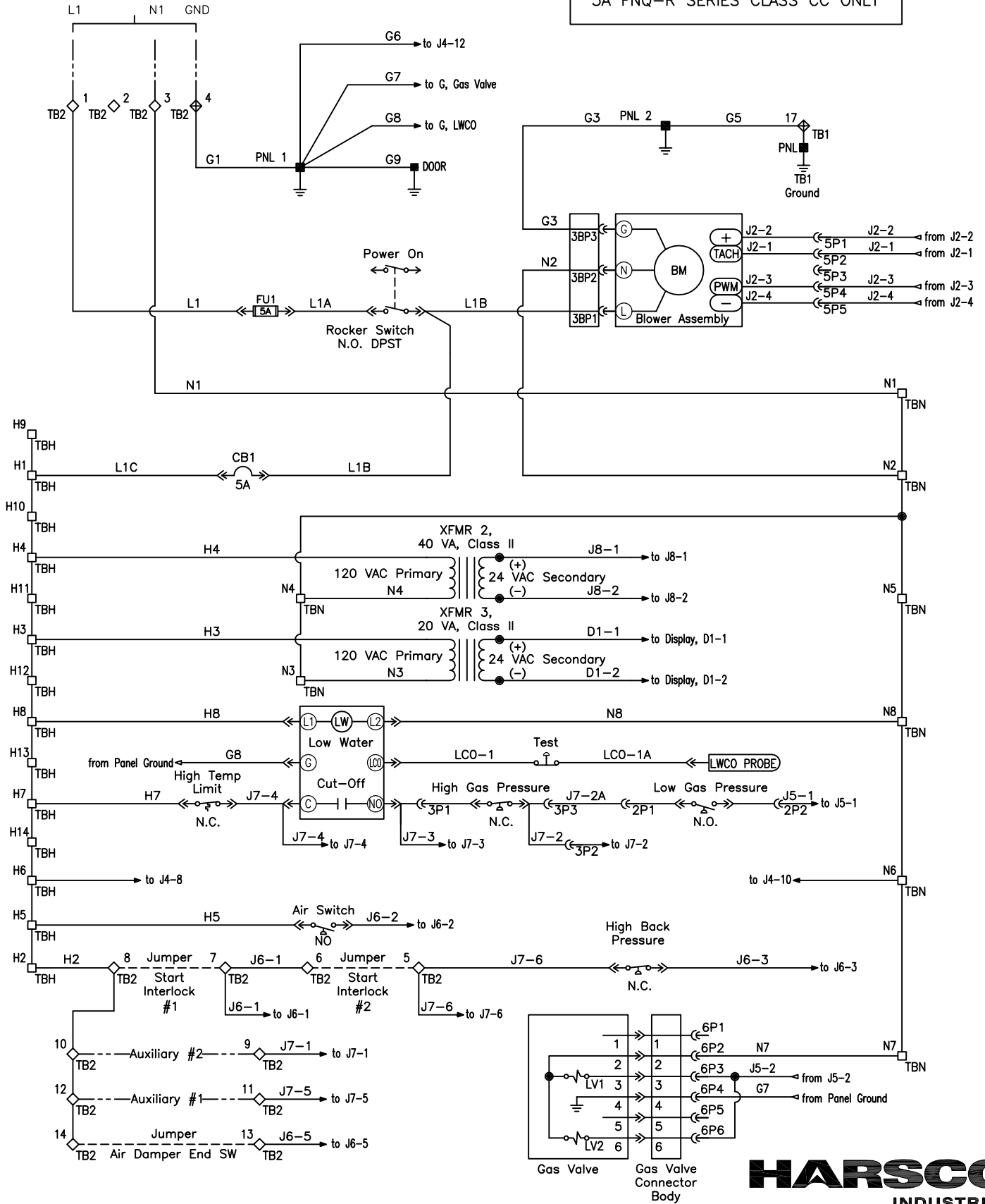

HARSCO
INDUSTRIAL
Patterson-Kelley
East Stroudsburg, PA 18301
570-476-7261
www.harscopk.com

IF ANY OF THE ORIGINAL WIRE SUPPLIED WITH THIS BOILER MUST BE REPLACED, IT MUST BE REPLACED WITH THE SAME UL WIRE TYPE.

CM399-CM500 / 120 VOLT
NURO™ Control

265100024 (1)
REV. C

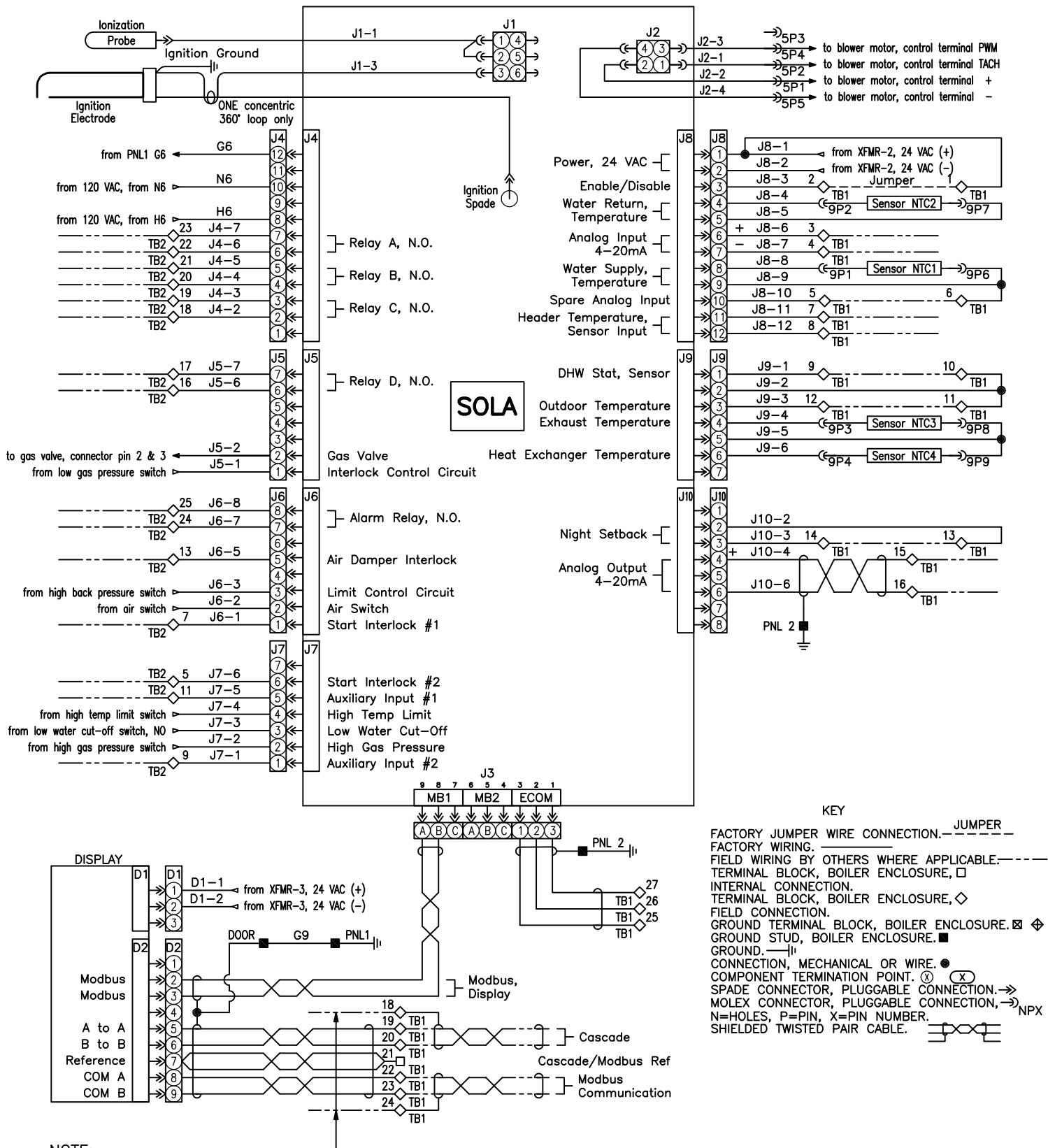

NOTE:
 Modbus and or Cascade field wiring must utilize twisted pair shielded cable. For multi boiler installations, JUMPER the field Modbus and or Cascade shield connection" TB1-18 and or TB1-24" to PNL ground in Master boiler TB1 terminal box. Do not ground shield to any other boiler or piece of equipment. Shield should be continuous from beginning to end with a ground connection in the master boiler only.

HARSCO
INDUSTRIAL
 Patterson-Kelley
 East Stroudsburg, PA 18301
 570-476-7261
 www.harscopk.com

IF ANY OF THE ORIGINAL WIRE SUPPLIED WITH THIS BOILER MUST BE REPLACED, IT MUST BE REPLACED WITH THE SAME UL WIRE TYPE.

CM399-CM500 / 120 VOLT
 NURO™ Control

2651000024 (2)
 REV. C