

SERIES WFT

FLOAT & THERMOSTATIC STEAM TRAP

INSTALLATION INSTRUCTIONS

INSTRUCTION PART NO. 2251800 REVISION D

INSTALLATION

1. Before installing the trap, blow out piping thoroughly to remove loose scale and dirt. Use pipe dope or teflon tape sparingly when attaching the trap to the pipe. Observe the pressure limitation shown on the trap label.
2. Install the trap below the equipment being drained in a location easily accessible for maintenance and inspection. Be certain to install with flow in direction indicated on diagram.
3. Install a drip pocket to keep dirt away from the trap.
4. Discharge piping should be amply sized to avoid excessive back pressures.
5. To provide for easy maintenance and service, install a block valve on each side of the trap and install a strainer ahead of the inlet connection.
6. All valves should be full ported to achieve the rated capacity of the trap.
7. If discharge piping is to be elevated, be certain that the available differential pressure is adequate to permit proper drainage. Remember, two feet of lift equals approximately one psig.

MAX. OPERATING PRESSURES

WFT-15	15 PSIG
WFT-30	30 PSIG
WFT-75	75 PSIG
WFT-125	125 PSIG
WFT-175	175 PSIG
WFT-250	250 PSIG

TROUBLESHOOTING

PROBLEM	CAUSE	ACTION
1. Trap does not discharge.	a) Damaged float. b) Operating pressure too high.	a) Replace float. b) Install trap suitable for operating pressure.
2. Trap does not close.	a) Dirt lodged on valve disc or thermostat seat area. b) Worn out internals; damaged thermostat.	a) Clean trap; replace thermostat; install strainer b) Replace internals or thermostat; be sure to match model no. and pressure

Each Watson McDaniel Company Product is warranted against defects in material and workmanship for one year from date of shipment. This warranty extends to the first retail purchaser only. All defective material must be returned to the person from whom you purchased the Product, transportation prepaid, free of any liens or encumbrances, and if found to be defective will be repaired free of charge or replaced, at the warrantor's or seller's option. If the material is replaced, any replacement will be invoiced in the usual manner and after inspection of alleged defective material an adjustment will be made for depreciation caused by purchaser's use. In no event will Watson McDaniel Company be liable to do more than refund the original contract price. Incidental and consequential damages are excluded, whether under this warranty or otherwise. All implied warranties, including warranties of merchantability and fitness for a particular purpose, are disclaimed and excluded.

TRAP MAY NOT EXACTLY MATCH THIS ILLUSTRATION

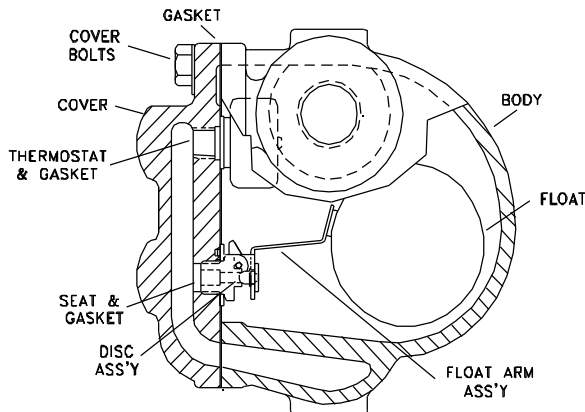

PMO	250 PSIG	PMA	250 PSIG up to 450°F
TMO	Sat. Steam Temp	TMA	450°F @ 250 PSIG

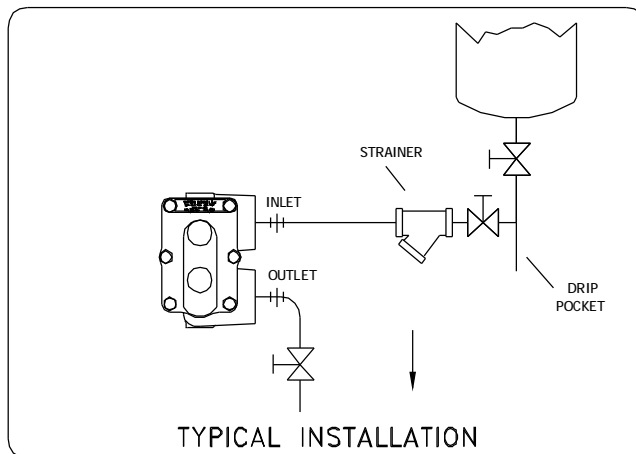

ORDERING SPARE PARTS

Specify the description of the part. Indicate the Model Number, Size, and Operating Pressure, which are shown on the name plate.

Typical Specification: Cover & Gasket for 2" WFT-125 steam trap