



# Condensing-Indirect Pool Heating

*Abstract:* In many athletic facilities pool heating is provided by a heat exchanger tied to the main heating boilers. While this works well enough during Winter months when additional space heating loads are present, it works poorly during those months when space heating is not required. When boilers are so large with respect to actual loads, they tend to short-cycle. Shortcycling significantly reduces fuel efficiency and causes accelerated wear-and-tear on large and expensive central plant machinery. Installing a "Summer boiler" is an old and time tested energy conservation strategy. The application of a small condensing pool heater for three season operation (together with a condensing domestic water heater) usually achieves fuel savings of 40% or more during the Summer months. This paper responds to those customers who have asked us how to do it, and introduces a new strategy for those applications where non-condensing boilers are used in this service.

## The Problem

When very large boilers try to satisfy very tiny loads, bad things happen. The rapid on-off cycling at low fire puts years of operating cycles on boiler components in just a few months, resulting in nuisance shutdowns and increased component replacement and maintenance costs. It is well known that this type of operation also increases fuel consumption due to purge losses and lower cycle efficiency. What is not generally known is just how expensive this can be. An old rule-of-thumb is that a short-cycling boiler achieves a maximum efficiency that is at least fifteen efficiency points lower than the lowest efficiency achieved by the boiler in non-short-cycling low fire. An atmospheric, high-low fired, flex-tube type watertube boiler that achieves 72% at low fire, for instance, achieves only 57% efficiency when it short-cycles.

This kind of efficiency degradation is compounded by the fact that the main heating boilers might be some distance from the pool, and the heating distribution loop has to be kept hot on a year-round basis. The distribution system will radiate heat to the building, adding to the Summer cooling load. Part

of the inefficiency caused by this type of operation might not show up on the gas bill: it's hidden in the electric bill as the result of higher chiller loads. Keep in mind, too, that to get the heat from the main heating boilers to the pool heat exchanger requires pumping energy (in a hot water heating system). That doesn't show up on the gas bill either.

Pools are usually heated to an operating temperature of 80°F or 82°F. An exercise pool in a facility that specializes in elder care might operate at temperatures up to 88°F. With proper heat exchanger sizing, it ought to be possible to heat pool water with a heating medium at somewhere around 110°F or 120°F and at a 20°F to 40°F  $\Delta T$ . A condensing boiler can operate in this temperature range and achieve ultra-high efficiencies when doing so. Most existing main plant heating boilers would be severely damaged if they were to operate at these temperatures. To satisfy the pool load at a 94% to 96% efficiency rather than at a 57% efficiency represents a 40% reduction in fuel consumption, and this doesn't include the electrical savings. It seems a shame to waste that much fuel.

## WHITE PAPER

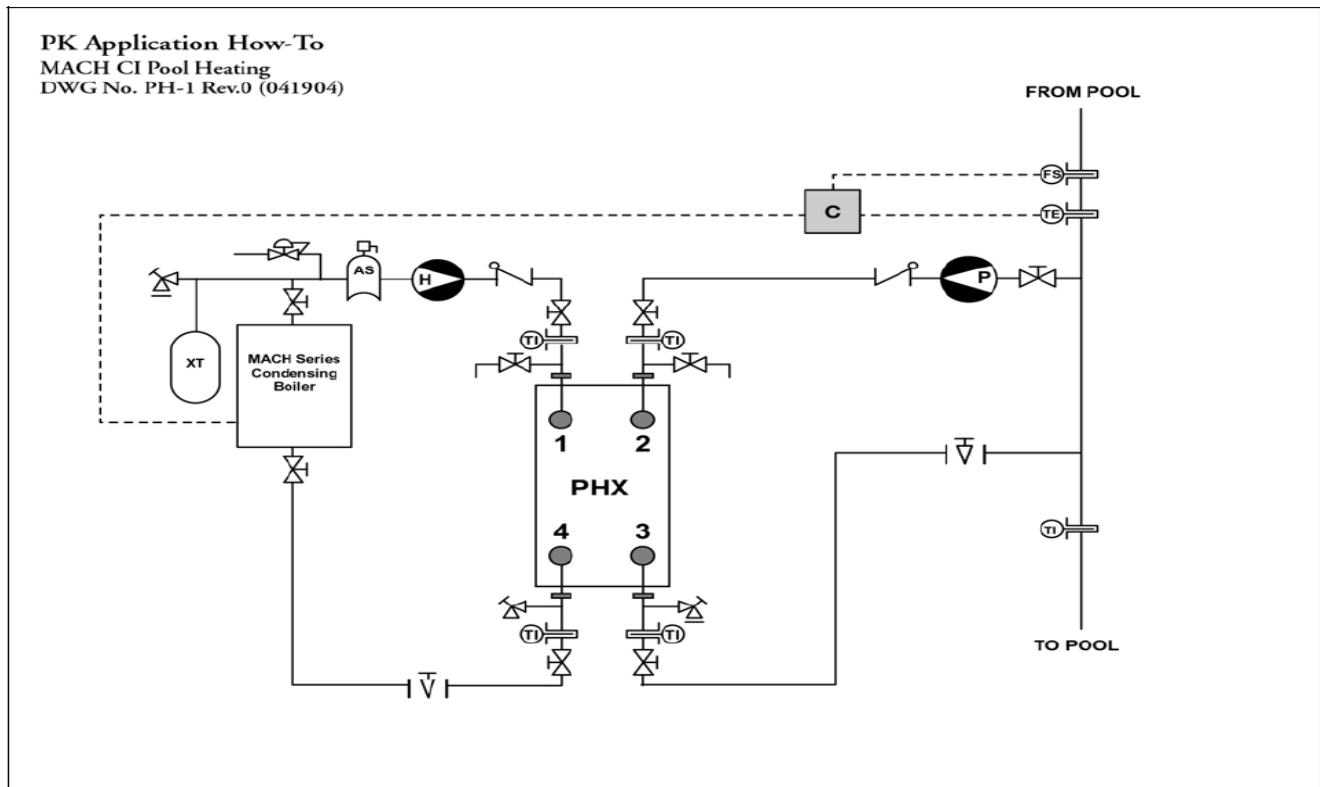

Figure 1. This is the basic arrangement for MACH CI Pool Heating. Note the primary-secondary connection to the pool filter main (the vertical line at the right of the drawing). It is a very simple system.

## Defining Requirements

Before presenting the solution, let's be clear about our objectives. There are four key requirements.

1. We must minimize the ownership cost of the condensing pool heating equipment. It does no good to save fuel dollars if we raise re-build and maintenance costs by an equivalent amount. The owner is no better off. Condensing pool heating equipment is more costly than any of the conventional atmospheric or fan-assisted options. The equipment we use has to last; in fact, it needs to have an indefinite life expectancy.

2. The solution must be an economic choice with a reason-

able payback. Operating efficiencies must be in the mid-to high-90's. A running load on a pool is small and consistent. When the system reaches equilibrium after startup, it ought to be possible to achieve consistently high efficiencies.

3. The high chloride content of pool water is highly corrosive, so the heat exchanger has to be built from appropriate materials. Most heat exchanger manufacturers offer various grades of stainless steel (some with a high molybdenum content) for pool heating, but they usually also specify chloride concentration limits as a condition of warranty. That seems completely impractical to us. Few, if any, of the participants in the engineering, construction or procurement process have any idea what the chemical parameters of pool

## WHITE PAPER



water treatment might be. Pool chemistry can and does vary within a range. The pool heat exchangers we use have to provide reasonable life in an uncertain environment.

4. The pool area and the pool heater mechanical room represent a highly corrosive atmosphere for any type of equipment, but especially for boilers. This problem is compounded whenever pool chemicals are stored in the same space in which the boiler operates. Some pool chemicals can even create poisonous byproducts when they are drawn into the boiler along with combustion air. Boiler manufacturers have been after owners for decades to store their boiler chemicals elsewhere, to no avail. This seems an ideal application for a sealed-combustion boiler.

### The Solution

Recent years have seen the introduction of low cost, plate-and-frame heat exchangers. As more and more manufacturers have entered the business, and as many European manufacturers (who at first manufactured their product for private labeling by American companies) have begun to market their products directly to the American trade without OEM mark-ups, costs are lower than ever. Heat exchangers for pool heating service fail eventually, so it seems reasonable to use something that provides good service life at minimal cost. These heat exchangers are ideally suited to this application.

The proposed system, which we call "condensing indirect pool heating," is illustrated in schematic form in Figure 1. Condensing-indirect pool heating is accomplished by creating a closed loop heating system that goes from boiler to heat exchanger and back to boiler. Pool water flows from the pool water filtration main, through the heat exchanger, and back to the pool water filtration main. The two connections in the main are located just a few inches apart, creating a classic "primary-secondary" configuration: flow will occur between the main and the heat exchanger only when a pump forces it to occur. The flow rate of pool water through the heat exchanger will be less than the filter flow rate.

Here's a good way to think about pool heating. From the boiler's point of view, the heat sink to which it is connected is an ocean. Since commercial pool filtration systems are generally sized to turn over the entire volume of the pool in

around 6 hours, the flow rate through the filter piping is like a river. What we're attempting to do is dump some heat from the boiler into a river that can carry it into the ocean. The flow rate in the river is high and the temperature rise we will create with our pool heating system is small. All we're trying to do is replace the heat lost from the pool due to radiation, convection and evaporation, and thereby maintain the pool at its operating temperature.

Back when we made longhand heat exchanger calculations, it was customary to make a graphical representation of the temperature requirements. Figure 2 shows what we are attempting here for a common application. Though this is a water heating application, we approach it as though it is a cooling application. Our objective is to be certain that whatever the boiler puts out can be transferred into the "river" and then into the "ocean." Boiler water enters at 120°F and exits at 90°F.

The pool water side represents an interesting problem in heat exchanger optimization. We're drawing water from the main that carries water from the filters back to the pool. The flow rate in that line is very large, and we have wide latitude in selecting a heat exchanger flow rate. We know that the heat exchanger will see its smallest size and minimum price when the flows on the two sides of the heat exchanger are roughly the same. So let's select the same temperature difference for both sides and assume that the water enters at 81°F and exits at 111°F. While this is simply too high for injection directly into the pool, we know that it will mix with the water in the main.

Given the flow rates that exist in a typical system, the net rise in the main will be on the order of 2°F, which is just about right.

Remember that all we're trying to do is dump whatever the boiler puts out into the main. The relative magnitude of flow rates will take care of the rest. Our protection from overheating the pool water comes from the fact that we've installed a flow switch in the main, and we cannot run the boiler unless there is flow in the main. Since the control point for boiler modulation is in the main and upstream of the secondary piping connections that connect the main to the heat exchanger, the boiler will modulate down from high fire only when the

## WHITE PAPER



temperature of the pool approaches its setpoint.

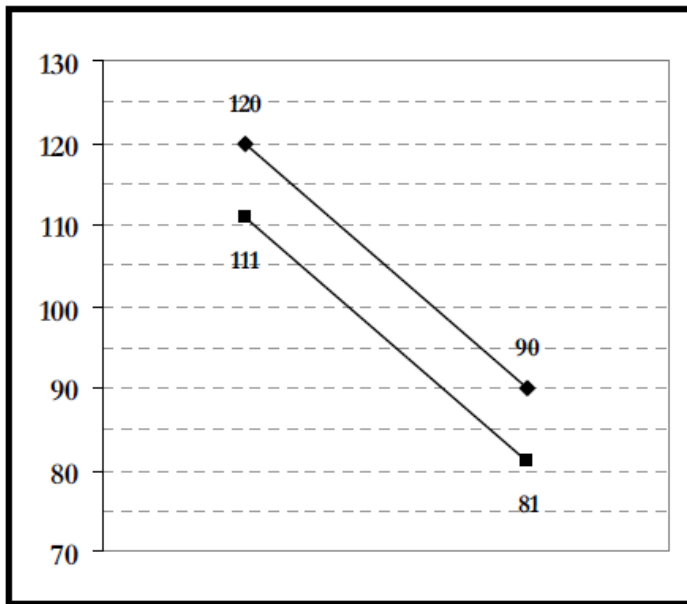

Figure 2

There is one commonly available option for materials of construction: 316 stainless steel. We believe that the heat exchanger should be furnished by the boiler manufacturer along with the boiler so that its capacity can be closely matched to the temperature conditions in the boiler.

### Special Considerations for Non-Condensing Boilers

Though the main focus of this article is the application of condensing boilers to pool heating, there will be applications where non-condensing boilers are preferred by an owner. In these cases special care must be taken to assure that return water enters the boiler at temperatures above the dew point temperature of the products of combustion of natural gas. This is not as easy to do as it might appear, particularly where a single pool water heat exchanger is used for all boilers.

The problem is that you can't control the supply and return boiler water temperatures by simply setting the boiler to operate at a certain temperature, e.g., 170°F. The water can't

read the operating schedule, and it's the heat and mass balance of the system that determines what happens to the temperatures. The temperature and volume of pool water entering the heat exchanger will act together with heat exchanger surface area to pull the temperature of the boiler loop down to the lowest temperature at which the setpoint controller in the pool water main can be satisfied. If there is enough surface area in the heat exchanger to satisfy the load at, for instance, a 5°F approach, the temperatures will fall to that level. Since the pool water temperature is what it is, the only way to effectively control the boiler's entering water temperature is to control the pool water flow rate at the entrance to the heat exchanger.

A simple way to do this is to use a variable speed circulator on the pool water side of the heat exchanger, and to vary its speed in accordance with the boiler's entering water temperature. This adds a setpoint controller to the system, and requires an upgrade from a standard circulator to a variable speed circulator. It will, however, provide highly reliable control, and will prevent destructive condensation from occurring in a noncondensing boiler. A system schematic has been included showing this option (see DWG. No. PH-4).

Non-condensing boilers can also be used as direct-fired pool heaters, thus eliminating the heat exchanger. The pool water would flow directly through the boiler. This application also requires a method of controlling the boiler's entering water temperature. The most common approach is to apply two balancing valves on the suction side of the boiler circulating pump (located at the boiler inlet), adjusting them so that just enough water is recirculated to raise it above the dewpoint.

It should be remembered that when the boiler is off its metal surfaces will cool to either the ambient temperature (if the pool pump is also turned off) or the pool water temperature (if the pool pump is left on). In either case the boiler metal surfaces will be cool, and condensation will occur, albeit for only a short time, on every start cycle. If the boiler is too large and start cycles are frequent, however, the boiler may not have enough run time to warm up and dry out: it will be damaged over time and the boiler's heat exchanger will eventually fail as the result of corrosion. Another approach is to use two boiler circulators instead of one. One is controlled by the boiler's entering water temperature, and the other is controlled

## WHITE PAPER



by boiler  $\Delta P$ . Together they provide consistent pool water flow at the desired entering water temperature. If the boiler is sized so that the pool's keep-warm load is within the boiler's modulating range, the system will achieve a steady state condition after a short time, and both flow and temperature will be optimal for long boiler life. A schematic diagram has been included for this type of system as well (see DWG. No. PH-5).

The principal disadvantage to direct-fired pool heating is that the heat exchanger will eventually have to be replaced. The replacement cost of a heat exchanger for an indirect system will certainly be significantly less than that of a boiler pressure vessel. Indirect systems nearly always have a lower life cycle cost.

## How To Size A System

Unfortunately, the ASHRAE Handbook is of little help in calculating a pool heating load or in sizing a pool heater. Additional guidance is needed.

There are actually two pool heating loads. First, there is the startup load which occurs when a pool is filled and brought to temperature. This is easy to calculate. Take the total pool volume, convert it to pounds of water (by multiplying by 8.33 lbs./ gal.), and multiply the result by the difference between the cold makeup water temperature and the pool's operating temperature. The number will be staggeringly large. There is actually more to the startup load than this, but we'll return to it again below.

Second, there is the pool's running, or keep-warm, load. Pools lose temperature in five ways.

1. The water heats the pool structure itself, which in turns conducts heat to the ground or surrounding building structure. In most applications this load is so small that it can be safely ignored.

2. There is a radiant load. The pool's surface acts as radiant surface, and so the pool radiates heat to the surrounding environment. This can be significant when all or part of the pool is located outdoors, and is especially large on a clear night when the pool radiates to a black body (the night sky). (It works the other way too: solar radiation heats a pool on a

sunny day.)

3. There is a convective heat loss at the surface of the water.

4. There is an evaporative load, as warm pool water evaporates from the surface of the pool into cooler surrounding air.

5. Finally, the evaporated water is replaced with cold water which has to be heated back to the pool's operating temperature.

For an indoor pool the evaporative load is largest, radiation and convection losses are small, and the makeup water load is smaller still.

Most boiler industry veterans have, over the years, developed a collection of rare and out-of-print graphs, tables, sizing formulas and technical articles which they rely upon for guidance in calculating loads and sizing boiler room components. One of the most valuable of these is an article from 1948 by S.J. Friedman. It may be the most detailed technical treatment of load calculations for open tanks, vats and kettles for water and other chemicals. It offers a rigorous method for making a reliable engineering estimate of heat loss from a pool. A copy of that article is appended to this white paper.

The magnitude of the evaporative load depends upon the temperature of the pool, the temperature and relative humidity of the surrounding air, and the air velocity across the pool's surface. For an indoor pool, you can assume that the air is still (or nearly so), the ambient temperature is 72°F (though it will seem higher because of high relative humidity), and the relative humidity is 70%. Most pools operate at 80°F to 82°F. Under these conditions a good rule-of-thumb is that an allowance of 75 BTUH/ sq. ft. of pool surface will cover all components of the load.

For example, a pool operating at these conditions with a surface area of 4,650 sq. ft. will have a keep-warm load of roughly 350,000 BTUH. If it contains 90,000 gallons of water, the startup load, on the other hand, is over 31,000,000 BTU. Note the difference in the magnitude of these loads. When we apply the Summer boiler concept to an indoor pool, we make the assumption that if the boiler is drained and refilled, the main plant boilers can be used to warm the pool water

## WHITE PAPER



to its operating temperature using the existing pool heat exchanger (should that be necessary). Keep in mind that the time allotted for startup on a pool can be from 72 hours to as long as a week. As this is a rare occurrence, we want to apply a small boiler to handle the keep-warm load only.

And this brings us back to the startup load. A keepwarm load occurs while the pool is first being brought to temperature. It starts at zero and climbs to its maximum value as the pool approaches its operating temperature. It is present nevertheless. Given the difference in magnitude between the two loads, however, this additional load is almost a rounding error. It might take a little longer to get the pool to temperature than it would if it were not present.

Cooler ambient temperatures and warmer pool temperatures increase keep-warm loads, and you should watch out for these conditions. Cooler ambient temperatures are common in athletic facilities in colleges and universities where competitive swim teams train, and warmer pool temperatures are common in facilities that cater to a more elderly clientele. But as a rule of thumb, 75 BTU/sq. ft. works well.

There is one additional consideration if you do a detailed heat load calculation based on the attached article. Once you calculate the evaporation load, you can divide the load by 1,000 to make a "good enough" estimate of the mass of water evaporated. This gives you the makeup volume, which can be multiplied by the temperature difference between the makeup water temperature and the pool's operating temperature to give the makeup water heating load (item 5 from the list above).

Where it is necessary to provide for both the startup load and the keep-warm load, you should apply a multi-boiler solution, and make sure that one of the boilers is small enough so that the keep-warm load is within its modulating range. The other boilers will be used for initial startup and will simply not be used otherwise (except when the small boiler is down for periodic inspection or maintenance).

If the only concern is the keep-warm load, use one heat exchanger per boiler and size it to transfer into the pool water everything the boiler can put out. If more than one boiler is required, arrange the pool water piping around the heat exchangers so that they are in parallel (see DWG. No. PH-2 and

PH-3). If there is an existing heat exchanger tied to the main boiler plant, leave it in place for startup duty and add one heat exchanger per boiler in accordance with the attached piping diagrams to handle the keep-warm loads. A number of piping schematics are included covering a variety of executions of this strategy. (See DWG. No. PH-1, 2 and 3.)

### Final Considerations

1. The energy savings are usually significant. Remember that the short-cycling efficiency of a main plant boiler will be significantly lower than its normal low-fire efficiency. The savings can be estimated from this equation:  $\text{Savings} = 100\% - (\text{Current Efficiency} / \text{New Efficiency})$ . Example: A MACH condensing-indirect pool heater replaces an oversized, main plant, atmospheric, high-low fired, flex-tube boiler. The MACH operates at 94% efficiency. The flex-tube normally makes 72% efficiency at low fire, but in shortcycling mode makes 57%. The savings would be 42% (not including the electrical energy savings discussed above).
2. There are very few commercial pools that wouldn't benefit from this strategy. Running main plant boilers on a year round basis just to heat a pool and some domestic water in the Summer is an operating practice that is hard to justify in today's energy environment. Savings of this magnitude make implementing this strategy affordable and attractive.
3. Simplicity in system design is a virtue. The attached system diagrams are simple in concept and execution.
4. The drawings are schematic. Always check the heat exchanger submittal drawing to determine the actual nozzle orientation for a specific installation.
5. Always contact your authorized Patterson-Kelley representative for support in developing plans and specifications. They can assist you in selecting the best schematic for your specific project, can support you with suggested specifications that are sensitive to local code requirements, and provide you with wiring schematics and other system details.

### Drawings & Tools

## WHITE PAPER



Published April 30th, 2004

For MACH CI Pool Heating:

PH-1: One boiler, one heat exchanger

PH-2: Two boilers, two heat exchangers

PH-3: Three boilers, three heat exchangers

For Modu-Fire Non-Condensing Pool Heating:

PH-4: One boiler, one heat exchanger (indirect)

PH-5: One boiler, no heat exchanger (direct)

**WHITE PAPER**







**PK Application How-To**  
MACH CI Water Heating  
DWG No. CI-2 Rev.0 (041904)

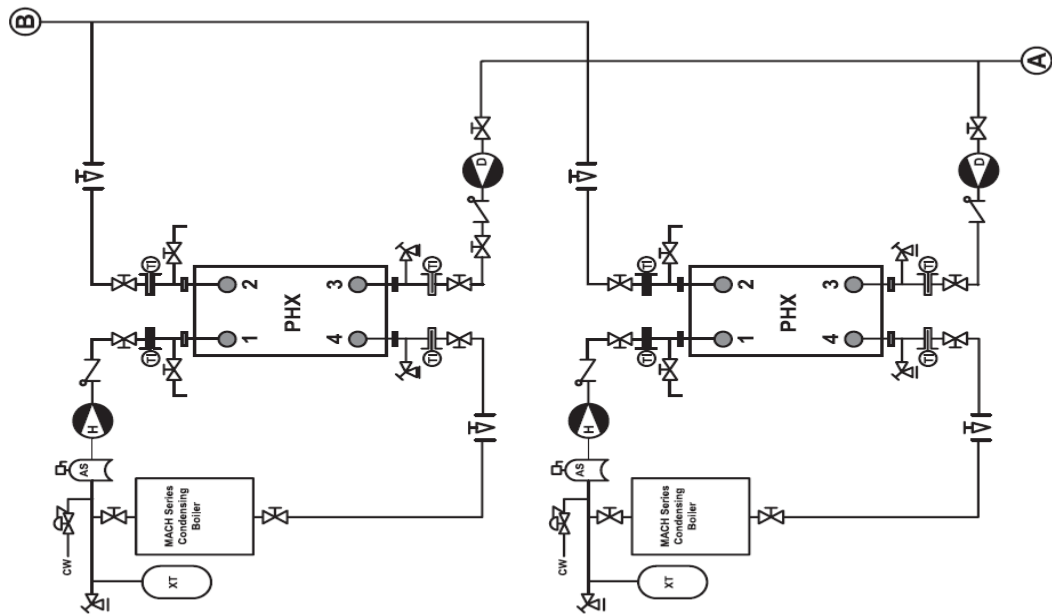

# WHITE PAPER

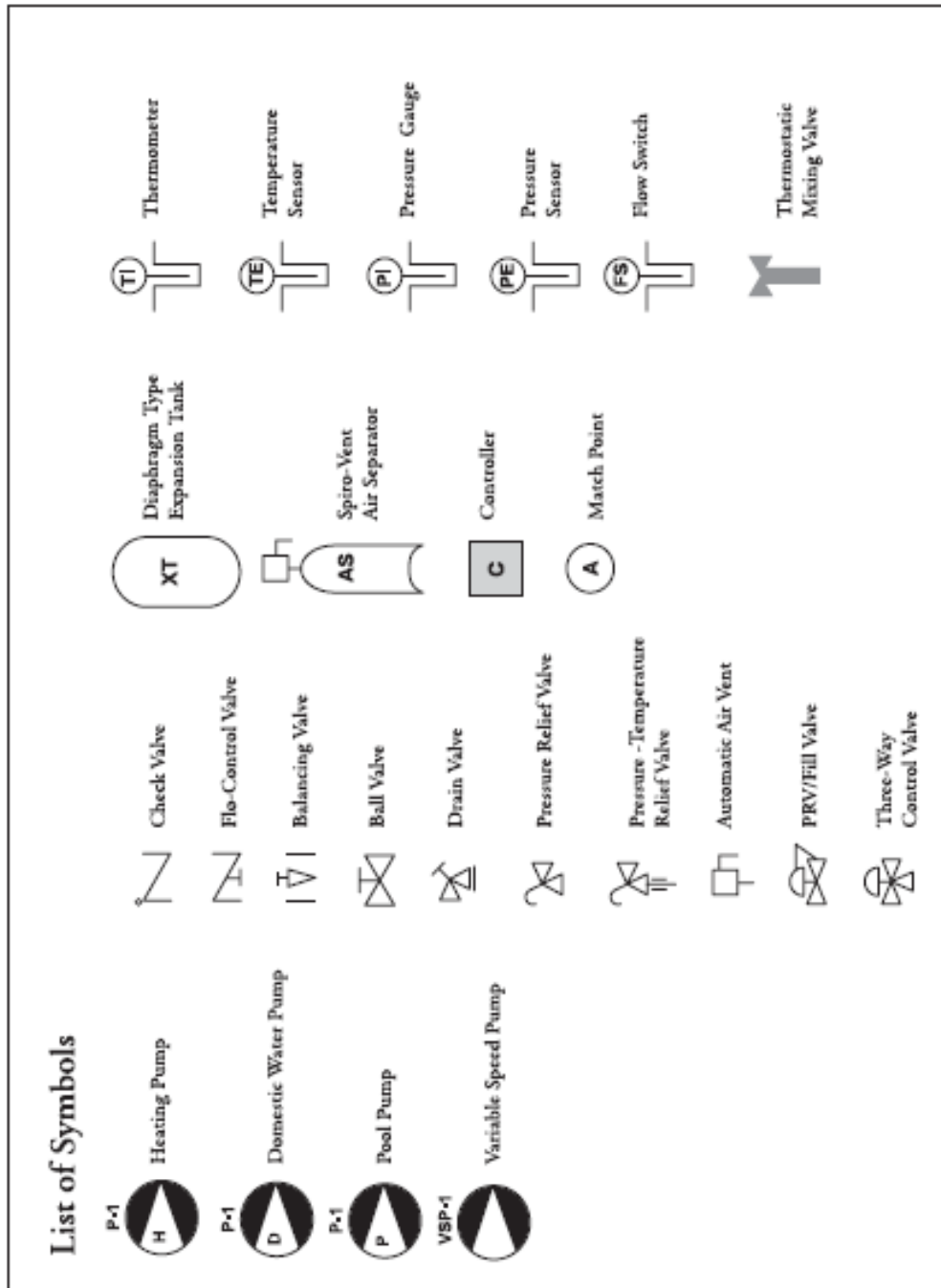



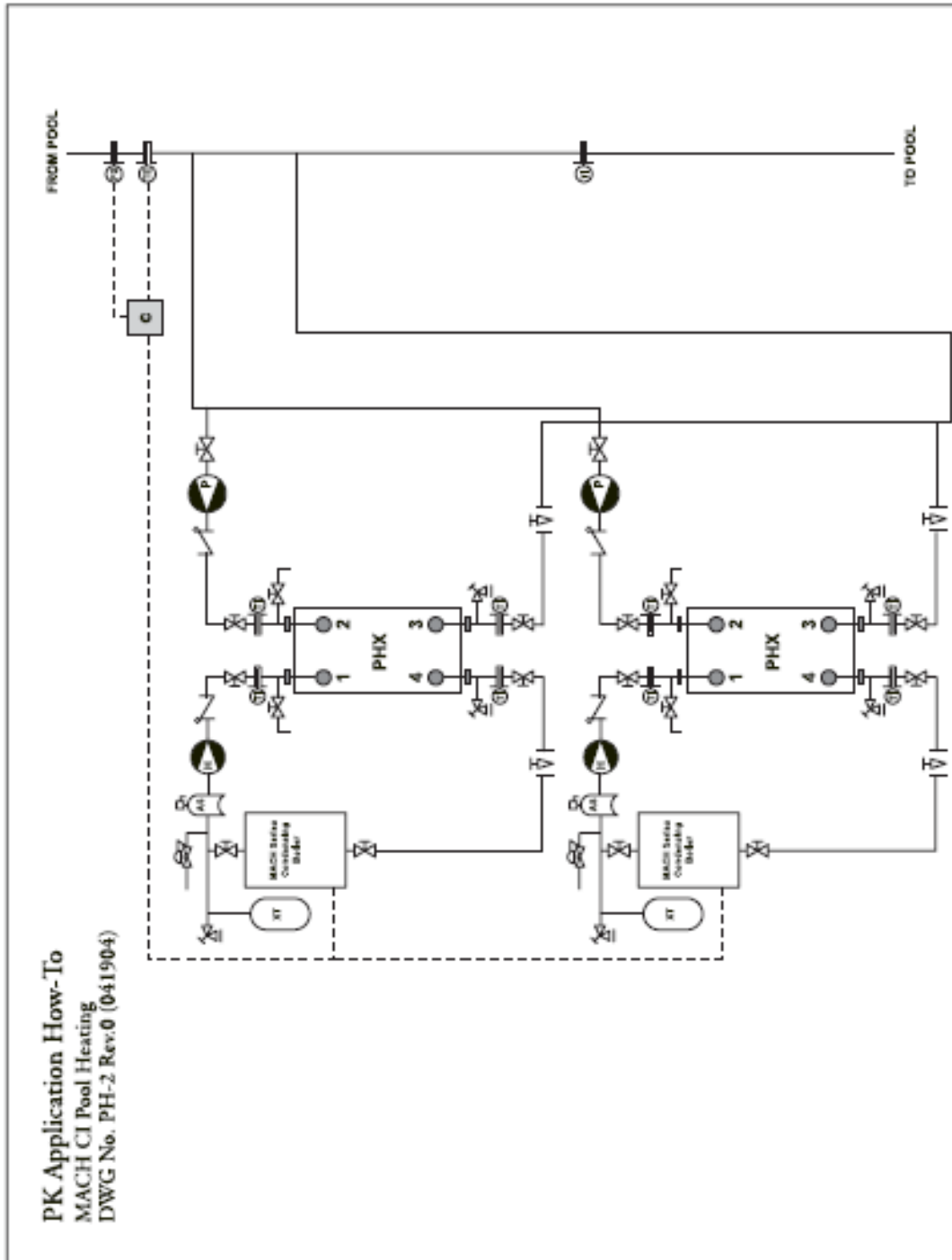

# WHITE PAPER

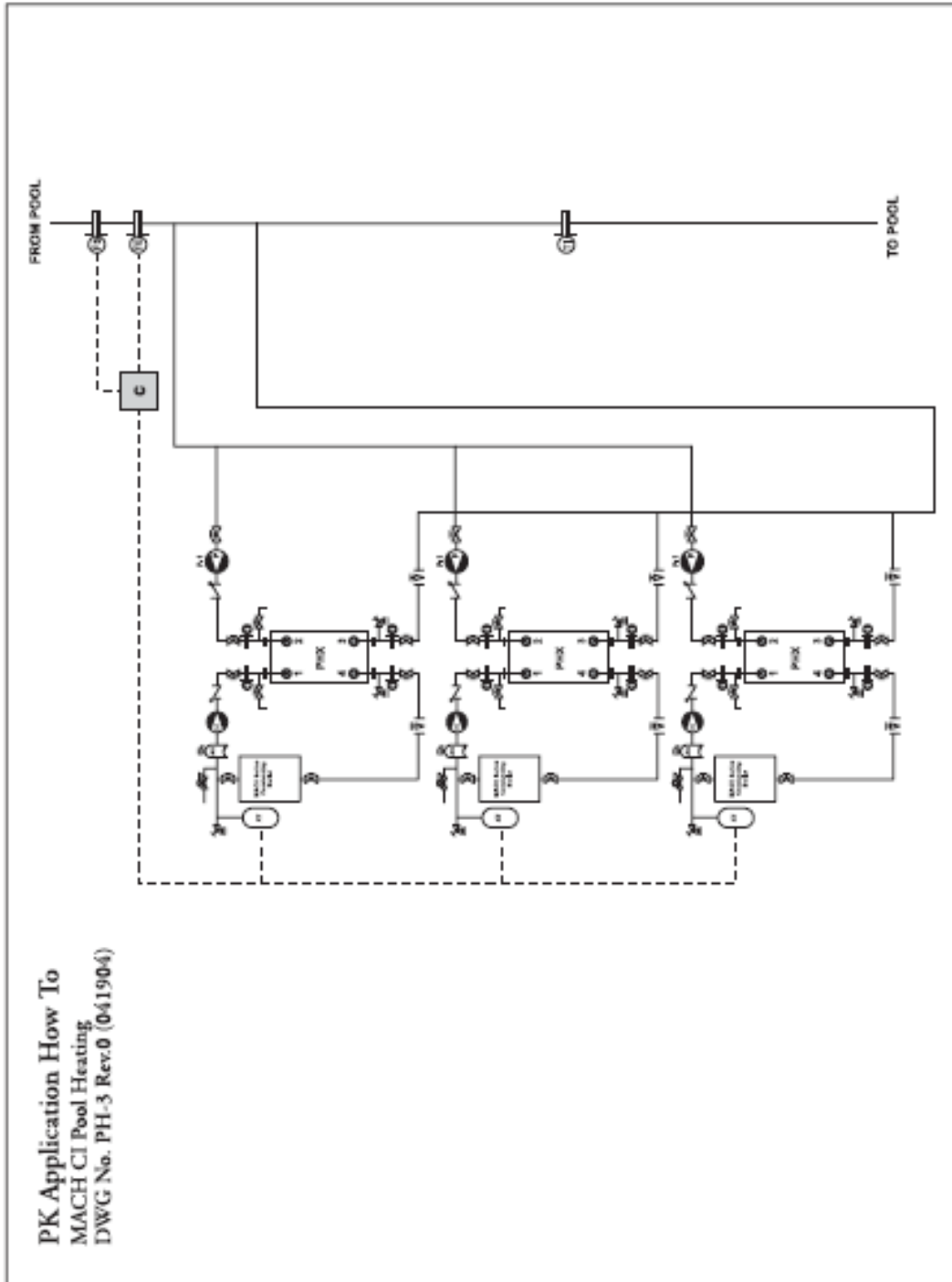

# WHITE PAPER

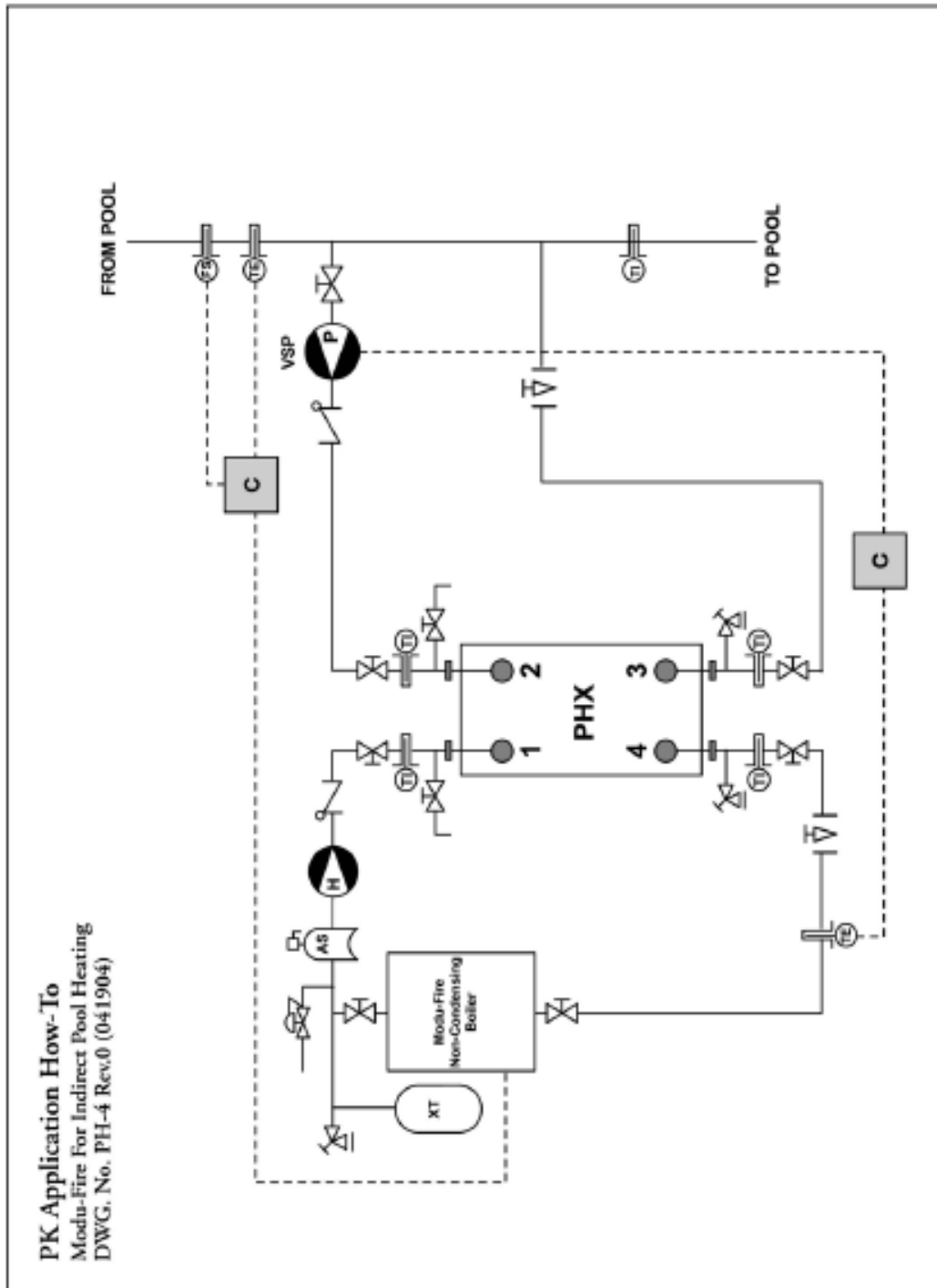

# WHITE PAPER

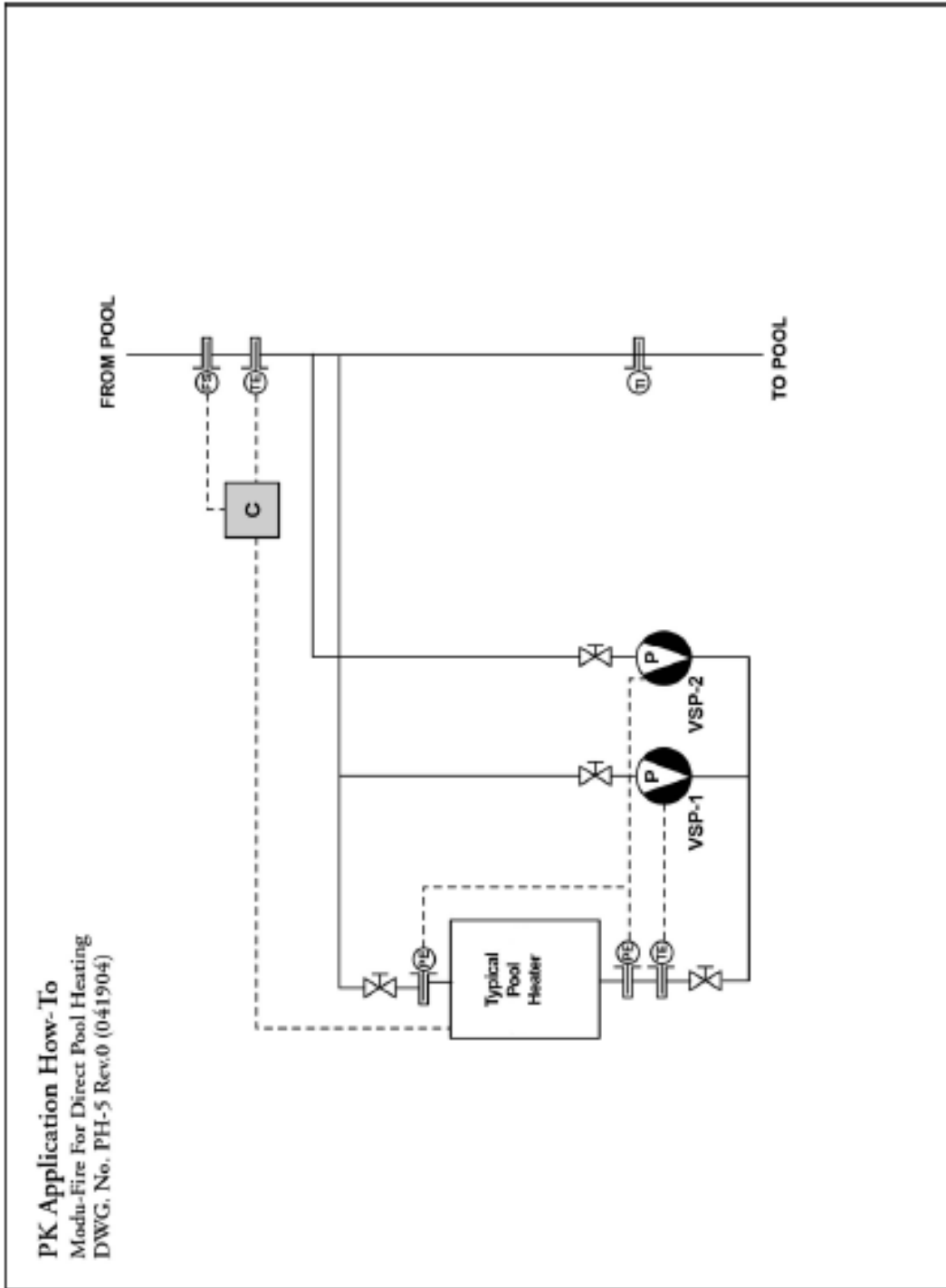

# WHITE PAPER