



PATTERSON-KELLEY

MODU-FIRE® FORCED DRAFT GAS-FIRED BOILER

Installation and Owner's Manual



C.S.A. Design-Certified
Complies with ANSI Z21.13/CSA 4.9
Gas-Fired Low Pressure Steam and Hot Water Boilers



ASME Code, Section IV
Certified by Patterson-Kelley



C.S.A. Design-Certified
Complies with ANSI Z21.13/CSA 4.9
Gas-Fired Low Pressure Steam and Hot Water Boilers

Installation Date: _____



Patterson-Kelley

Harsco

100 Burson Street, P.O. Box 458
East Stroudsburg, PA 18301
Telephone: (877) 728-5351, Facsimile: (570) 476-7247
www.pkboilers.com

INSTALLATION
& OWNER'S
MANUAL

INSTALLATION
& OWNER'S
MANUAL

INSTALLATION
& OWNER'S
MANUAL

INSTALLATION
& OWNER'S
MANUAL

INSTALLATION
& OWNER'S
MANUAL

INSTALLATION
& OWNER'S
MANUAL

INSTALLATION
& OWNER'S
MANUAL

INSTALLATION
& OWNER'S
MANUAL



1.0 INTRODUCTION	2	3.6 Vent Terminations.....	12
2.0 SAFETY.....	2	3.6.7 Venting for Multiple Boilers	13
2.1 General	2	3.6.8 Removing an Existing Boiler	13
2.2 Training.....	2	3.7 Gas Piping.....	14
2.3 Safety Features	2	3.8 Boiler Water Piping.....	15
2.4 Safety Labels	3	3.8.1 Piping Design	15
2.5 Safety Precautions.....	3	3.8.2 Boiler Water Connections	16
2.5.1 Electrical Hazards.....	3	3.8.3 Boiler Water Piping by Installer.....	16
2.5.2 Burn, Fire, and Explosion Hazards.....	3	3.8.4 Flushing and Filling	16
2.5.3 Crush Hazards.....	4	3.8.5 Water Quality	17
2.5.4 Chemical Hazards	5	3.9 Burner and Ignition System.....	17
2.5.5 Pressure Hazards.....	5	3.9.1 Inspection.....	17
2.5.6 Slip, Fall Hazards	5	3.10 Pre-Start Check List	17
3.0 INSTALLATION	6	3.11 Safety Checks	18
3.1 Receiving and Storage	6	3.11.1 Test of Ignition Safety System	18
3.1.1 Initial Inspection.....	6	3.11.2 Test of Low Water Cut-off.....	18
3.1.2 Storage Prior to Installation	6	3.11.3 Test of Limit Controls	18
3.2 Compliance with Codes	6	3.11.4 Test of Low Gas Pressure Switch.....	18
3.3 Setup.....	6	3.11.5 Test of High Gas Pressure Switch....	19
3.3.1 Foundation.....	6	3.12 Initial Adjustments	19
3.3.2 Placement.....	6	3.12.1 Configuring the Temperature Control	19
3.3.3 Installation Clearances	7	3.12.2 Air Flow Adjustment.....	21
3.4 Electrical Connections	7	3.12.3 Fuel/Air Ratio Adjustment.....	21
3.5 Combustion Air	9	4.0 OPERATION	22
3.5.1 Sealed Combustion	9	4.1 General.....	22
3.5.2 Intake Duct Materials and Sizes.....	10	4.1.1 Normal Operation.....	22
3.5.3 Sealing the Intake Duct	10	4.2 Lighting and Shut-Down Procedures	22
3.5.4 Intake Duct Connection to Boiler.....	10	4.2.1 Initial Lighting Procedures.....	22
3.5.5 Intake/Exhaust Layout	10	4.2.2 Normal Shut Off Procedures.....	23
3.6 Venting (Stack)	10	4.2.3 Emergency Shut Off Procedures	23
3.6.1 Vent Components.....	11	4.3 Typical Boiler Operating Conditions.....	23
3.6.2 Barometric Damper	11	5.0 MAINTENANCE	24
3.6.3 Automatic Vent Damper	11	5.1 Maintenance and Inspection Schedule	24
3.6.4 Flue Connection	11	5.1.1 Daily	24
3.6.5 Clearances	11	5.1.2 Weekly	24



5.1.3 Monthly	24	6.1.3 Main Control Panel Point to Point	33
5.1.4 Annually	25	6.1.4 Junction Box Point to Point and Customer Connections	34
5.2 Cleaning the Burner	25	6.1.5 Customer Connections Details	35
5.3 Removing the Exchanger	26	6.1.6 Gas Train	36
5.4 After All Repairs or Maintenance	26	6.1.7 Blower/Burner/Ignition Assembly	37
5.5 Sequence of Operation	27	6.1.8 Heat Exchanger and Combustion Chamber	38
5.6 Troubleshooting	28	6.1.9 Cabinet Assembly	39
6.0 PARTS/TECHNICAL SUPPORT	30	7.0 LIMITED WARRANTY	40
6.1 Schematic Diagrams	30	8.0 FIELD STARTUP REPORT	41
6.1.1 Wiring Schematic	31		
6.1.2 Main Control Panel Components	32		



WARNING!

It is **essential** to read, understand, and follow the recommendations of this manual before installing, operating, or servicing this equipment. Failure to do so could result in fire or explosion and serious injury, death, and/or property damage.

The same features which permit this boiler to achieve high-efficiency performance make it unlike most other boilers of this general size. It is important to understand how this boiler operates by reading this manual.

WARNING!!

Do not store or use gasoline or other flammable vapors or liquids in the vicinity of this or any other appliance.

WARNING!

Installation and service must be performed by a qualified and knowledgeable individual such as a PK representative, qualified installer, service agency, or gas supplier.

What to do if you smell gas:

- Do not try to light any appliance.
- Do not touch any electrical switch; do not use any phone in your building.
- Immediately call your gas supplier from a neighbor's phone. Follow the gas supplier's instructions.
- If you cannot reach your gas supplier, call the fire department.



1.0 INTRODUCTION

The **MODU-FIRE® FORCED DRAFT** Gas-Fired Boiler is a revolutionary advance. Patterson-Kelley now combines full-modulation burner control and forced draft advances with our time-tested modular hot water boiler design. The result is a full-modulation boiler utilizing reduced vent sizing for installation and cost efficiencies. This boiler combines the best of our earlier designs with a new generation of burner, control and operating technology. You will achieve high part-load efficiencies – but without the complexity you might expect in this type of high performance boiler. It is high performance made simple and dependable for years of trouble-free operation.

This manual covers installation of the **MODU-FIRE® FORCED DRAFT (MFD)** Boiler series 1500 and 2000. The model numbers may include a prefix and will include a suffix to indicate special features or different options. While details may differ slightly, basic operation is the same for all models. Boilers are built to operate with natural gas or propane. Check the rating label for the correct gas type and flow rate.

The boiler is only a part of the complete heating system. This boiler may be fully operational and yet, because of poor circulation, controls, or other operating characteristics, not deliver heat to the desired location. Additional equipment such as temperature sensors, pumps, flow switches, balancing valves and check valves will be required for satisfactory operation of any system. Patterson-Kelley cannot be responsible for the design or operation of such systems and a qualified engineer or contractor must be consulted.

2.0 SAFETY

2.1 GENERAL

The **MODU-FIRE® FORCED DRAFT** gas-fired boiler **must** be:

- Installed in accordance with designs prepared by qualified facility engineers including: structural,

mechanical, electrical, and other applicable disciplines.

- Operated and serviced in accordance with a comprehensive safety program determined and established **by the customer**. Do not attempt to operate or service until such a program has been established.
- Operated and serviced by qualified and knowledgeable personnel in accordance with all applicable codes, laws, and regulations.
- The use of the term “factory-trained personnel” throughout this manual indicates Patterson-Kelley trained on this specific piece of equipment.

2.2 TRAINING



It is **essential** to read, understand, and follow the recommendations of this manual before installing, operating, or servicing this equipment. Failure to do so could result in serious injury, death, and/or property damage.

Proper training is the best protection against accidents. Operating and service personnel must be thoroughly familiar with the basic construction of the **MODU-FIRE® FORCED DRAFT** boiler, the use and locations of the controls, the operation of the boiler, adjustment of its various mechanisms, and all applicable safety precautions. If any of the provisions of this manual are not fully and completely understood, contact the Patterson-Kelley Technical Services Department.

2.3 SAFETY FEATURES

It is the responsibility of the customer to maintain the safety features of this machine, such as: guards, safety labels, safety controls, interlocks, lockout devices, etc., in place and operable.



2.4 SAFETY LABELS

The following words are used in this manual to denote the degree of seriousness of the individual hazards.

DANGER – Used to indicate an imminently hazardous situation which, if not avoided, **will** result in death or serious injury. This signal word is to be limited to the most extreme conditions.

WARNING – Indicates a potentially hazardous situation which, if not avoided, **could** result in death or serious injury.

CAUTION – Used to indicate a potentially hazardous situation which, if not avoided, **may** result in minor or moderate injury.

NOTICE/NOTE - NOTICE is the preferred signal word to address practices not related to personal injury. The safety alert symbol is not used with this signal word.

The safety labels shown below are affixed to your boiler. Dual language labels may be affixed to your boiler. Although the labels are of high quality, they may become dislodged or unreadable over time. Contact Patterson-Kelley for replacement labels.

2.5 SAFETY PRECAUTIONS

Provide a suitable location for the boiler, away from normal personnel traffic, with adequate working space, adequate clearances, proper ventilation and lighting, with a structure sufficiently strong and rigid to support the weight of the boiler, all piping, and accessories.

Proper lockout/tagout procedures must be employed whenever this unit is serviced.

2.5.1 Electrical Hazards



- Shock hazard! Properly lockout/tagout the electrical service and all other energy sources before working on or near the machine.
- Shock hazard! Boiler is not rated for wash-down service.
- Power down unit for at least 10 minutes before servicing inverter or blower.

2.5.2 Burn, Fire, and Explosion Hazards



General Warning



Hot Surface

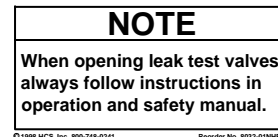
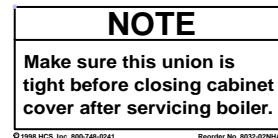

- Burn, fire, and explosion hazards! Installation must be in strict conformance to all applicable codes and standards including NFPA 54, ANSI Z223.1 and CSA B.149.
- Hazard from incorrect fuels! Possible fire, explosion, overheating, and damage. Do not use any fuels except the design fuel for the unit.



- Overfire hazards! High pressure in gas or propane supply could result in overfiring of other devices supplied from the same source.
- Fire and explosion hazards! Close the main gas shutoff before servicing boiler.
- Fire and explosion hazards! Do not store or use gasoline or other flammable vapors or liquids in the vicinity of this or any other gas fired appliance.
- Burn hazard! Possible hot surfaces. Do not touch the stack during firing operations. Use only factory recommended vent components.
- Burn hazard! Hot fluids. Use caution. Allow boiler to cool before servicing or draining boiler.
- Fire and explosion hazards! Use caution when servicing burner or heat exchanger. Fuel may linger in the combustion chamber, vent lines, or elsewhere.
- Gas leak hazard! Make sure all connections to main burner are tight when reassembling the burner.

NOTE
Make sure this union is tight before closing cabinet cover after servicing boiler.
<small>©1999 HCS, Inc. 800-748-0241 Reorder No. 9032-021WAK</small>

- Gas leak hazard! All threaded gas connections must be made using a pipe compound that is resistant to liquefied petroleum. **Do not** use Teflon tape on threaded gas piping.
- Gas leak hazard! Check entire gas train for leaks after installation. If there is a smell of gas, shut down the boiler, close all gas valves and obtain immediate assistance from factory-trained personnel and/or your local fire department.
- Overfire hazard! Possible fire and explosion from excess gas pressure. Make sure that gas inlet pressure does not exceed 14 inches W.C. to the boiler main gas valve.
- Overfire hazard! Possible fire and explosion. Possible malfunction of regulators and/or gas valves. Maintain all gas train components in good condition. Do not alter wiring connections.

Annual inspection by factory-trained personnel for proper set-up and operation is recommended.

- Overfire and underfire hazards! Possible fire, explosion, overheating, and component failure. Do not attempt to adjust firing rate of the boiler. The firing rate must be adjusted **only** by factory-trained personnel.

2.5.3 Crush Hazards



General Warning

- Lifting hazards! Use properly rated lifting equipment to lift and position the boiler. The load is unbalanced. Test balance before lifting 3 ft. above the floor. Do not allow personnel beneath the lifted load. Refer to approximate weights in the table below:

Boiler Size	Weight in Pounds
1,500,000 Btu	915
2,000,000 Btu	930

- Bump hazard from overhead piping. Install piping with adequate vertical clearance.



2.5.4 Chemical Hazards



General Warning

- Chemical hazards from cleaning products. Use caution when cleaning the system. The use of professional assistance is recommended. Use safe procedures for the disposal of all cleaning solutions.

2.5.5 Pressure Hazards



- Pressure hazard! Hot fluids. Install isolation valves on boiler water inlet and outlet. Make sure isolation valves are closed before servicing boiler.
- Pressure hazard! Hot fluids. Test safety relief valve bimonthly for proper operation. Do not operate boiler with faulty relief valve.

2.5.6 General Hazards



General Warning

- Tripping hazard! Do not install piping on floor surfaces. Maintain clear path around boiler.
- Slip and fall hazard! Use drip pan to catch water while draining the boiler. Maintain dry floor surfaces.
- Slip and fall hazard! Through-the-wall vents shall not terminate over public walkways or over an area where condensate or vapor could create a nuisance or hazard.
- Fall hazard! Do not stand on any part of the boiler.
- Catch hazard! Do not wear rings, jewelry, long hair, loose clothing while working on the boiler.



3.0 INSTALLATION

WARNING!
Installation and service must be performed by a qualified installer, service agency, or gas supplier.

3.1 RECEIVING AND STORAGE

3.1.1 Initial Inspection

Upon receiving the boiler, inspect it for signs of shipping damage.

Important: Note any damage or shortage on the freight bill and immediately notify the carrier. File all claims for shortage or damage with the carrier.

3.1.2 Storage Prior to Installation

If the boiler is not installed immediately, it must be stored in a location adequately protected from the weather, preferably indoors. If this is not possible, then it should remain in the shipping container and be covered by a tarpaulin or other waterproof covering.

Notice: Controls and other equipment that are damaged or fail due to weather exposure are not covered by warranty.

3.2 COMPLIANCE WITH CODES

The **MODU-FIRE® FORCED DRAFT** Boiler with standard components and many options complies with American National Standard/CSA Standard ANSI Z21.13/CSA 4.9, latest edition, Gas-Fired Low Pressure Steam and Hot Water Boilers. The heat exchanger is constructed and stamped in accordance with ASME Boiler and Pressure Vessel Code, Section IV for 160 psig maximum operating pressure and/or 250° F maximum operating temperature. Other codes or approvals which apply will be labeled on the boiler.

Installation of the boiler must conform to all the requirements of all national, state and local codes es-

tablished by the authorities having jurisdiction or, in the absence of such requirements, in the U.S. to the National Fuel Gas Code, ANSI Z223.1/NFPA 54, latest edition, and the specific instructions in this manual. In Canada, the equipment shall be installed in accordance with the current Installation Code for Gas Burning Appliances and Equipment, CSA-B.149, and applicable Provincial Regulations for the class, which should be carefully followed in all cases. Authorities having jurisdiction should be consulted before installations are made.

Where required by local codes, the installation must conform to American Society of Mechanical Engineers Safety Code for Controls and Safety Devices for Automatically Fired Boilers (ASME CSD-1).

In the Commonwealth of Massachusetts, see Massachusetts Installation & Owner’s Manual Supplement.

3.3 SETUP

3.3.1 Foundation

Provide a firm, level foundation, preferably of concrete.

Caution: The boiler may be installed on a combustible floor; however, the boiler must **never** be installed on carpeting.

Caution: This boiler is certified for **indoor** installation only.

3.3.2 Placement

The boiler must be level and upright to function properly.

Use shims or other approved structural devices to properly level boiler.



3.3.3 Installation Clearances

If the boiler is to be installed near combustible surfaces, six (6") inches minimum clearance to the combustible surface must be maintained.

Failure to provide for the service access clearances, even with non-combustible surfaces, may cause future problems servicing the boiler.

The boiler must be installed in a space large in comparison to the boiler as described in the National Fuel Gas Code, ANSI Z223.1, Latest Edition.

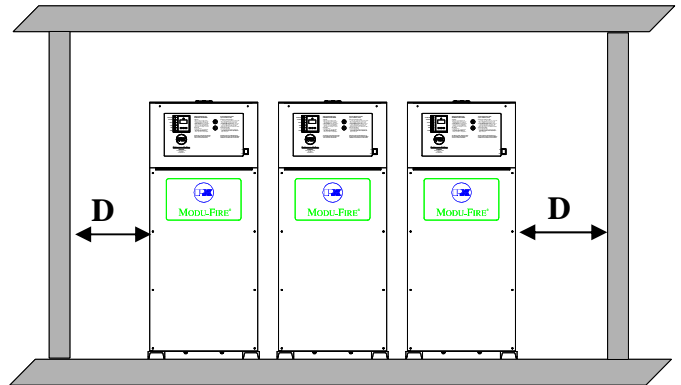

Side Clearances for a Row of Boilers

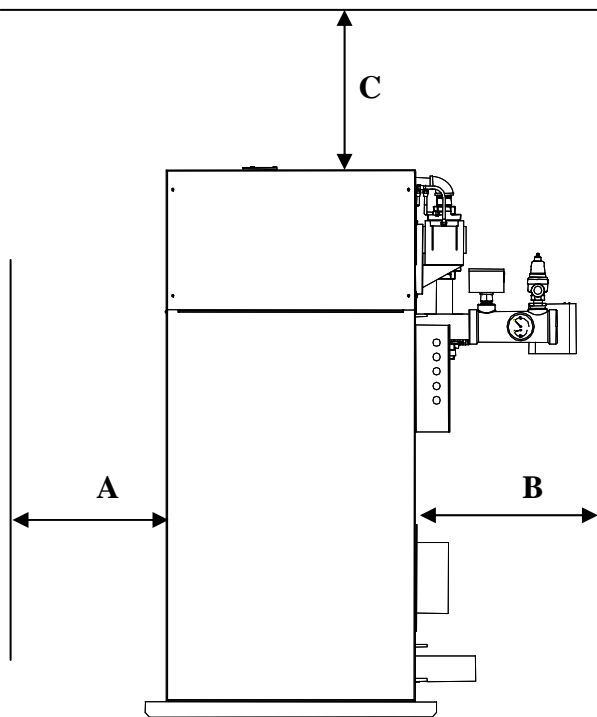

Clearances from Adjacent Walls, Ceiling, and Obstructions

Type of Surface	Dimensions (inches)			
	A	B	C†	D
Recommended Service Clearances	30	24*	24	24**

† "C" dimension includes clearance to remove the burner. Do not put pipes, ducts, etc. in this area above the boiler.

* CSA minimum. Actual clearance depends upon venting requirements.

** Service access need be only on one side of a boiler or row of boilers. Boilers may be installed immediately adjacent to each other. However, P-K recommends this clearance between **each boiler** when there is insufficient access at the rear to allow for service and adjustment.

3.4 ELECTRICAL CONNECTIONS

All field wiring connections for power and controls are in the junction box on the back of the boiler. The boiler wiring label is attached to the inside front door of the boiler. An external electrical disconnect (not supplied with the boiler) with adequate overload protection is required. The boiler must be grounded in accordance with local codes or in the absence of such requirements, in the U.S. with National Electrical Codes, ANSI/NFPA No. 70 latest edition and in Canada, wire according to the current Canadian Electrical Code.



Notice: A dedicated earth ground (green wire) is required to avoid nuisance shutdowns. Do not ground through the conduit. It is also important that proper polarity be maintained.

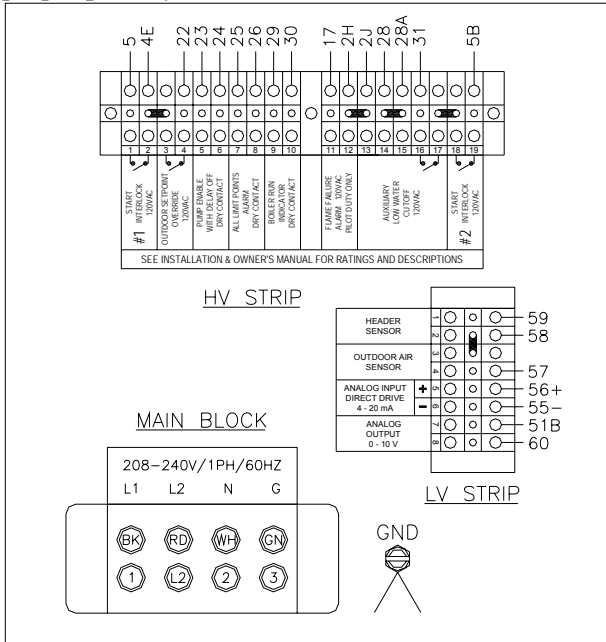

Boiler Electrical Connections

The junction box at the rear of the boiler contains terminal strips for power and control connections. These connections are described as follows:

Power Terminal Block

The boiler power circuit requires 208-240 volts, single phase, 60 hertz, with a dedicated neutral for the control circuit as labeled. The voltage from each line (L1, L2) to the neutral must be approximately 115V AC. The 1500 & 2000 series boilers require less than 12 amps. Before starting the boiler, check to ensure that the proper voltage and amperage are connected to the boiler and that the boiler is connected to a suitable fused disconnect switch.

High Voltage (HV) Strip

#1 Start Interlock – Use for boiler enable. Closing this circuit allows the boiler to run. Opening this circuit prevents the boiler from running, provided the remote/local enable switch is in the remote position. This circuit is energized by the boiler. It has a 120VAC potential. Devices connected to these terminals must be rated for 120VAC and 5 Amps.

WARNING: The remote/local switch bypasses the #1 start interlock when in the local position. Do not connect safety devices into #1 start interlock

Outdoor Air Override – Use for override of outdoor air schedule. Closing this circuit overrides the outdoor air reset schedule to a fixed setpoint. Opening this circuit allows the control to reset the setpoint based on outdoor air temperature when in outdoor air reset mode. This circuit is energized by the boiler. It has a 120VAC potential. Devices connected to these terminals must be rated for 120VAC.

Pump Enable w/Delay Off - This contact closes when there is a call for heat. When the call for heat is removed, the contact remains closed for a period of time. Dry contact with a 120VAC 1 Amp max rating. (See 3.12.1)

All Limit Points Alarm (ALPA) – Pilot duty alarm contact that is closed if the boiler does not start within five minutes of receiving a call for heat. Dry contact with a 120VAC 1 Amp max rating.

Boiler Run Indicator – This contact closes when the flame is on. Dry contact 120VAC 1 Amp max rating.

Flame Failure Alarm – Alarm output from the flame safeguard control. This circuit is energized by the boiler. It has a 120VAC potential with a max rating of 1 Amp.

Auxiliary Low Water Cutoff – These terminals are used for connection of a low water cutoff. This circuit is energized by the boiler. It has a 120VAC potential. Devices connected to these terminals must be rated for 120VAC and 5 Amps.

#2 Start Interlock - Use for additional field safety device to close this circuit. Closing this circuit allows the boiler to run. Opening this circuit prevents the boiler from running. This circuit is energized by the boiler. It has a 120VAC potential. Devices connected to these terminals must be rated for 120VAC and 5 Amps.



Low Voltage (LV) Strip

Header Sensor – Connected when a header sensor is used. The temperature control should be in Mode 2 or 5. The sensor is available from the local P-K Representative.

Outdoor Air Sensor – Location for outdoor air sensor wires to be connected. The temperature control should be in Mode 4 or 5. The sensor is available from the local P-K Representative.

Analog Input Direct Drive – Remote signal for controlling the boiler firing rate directly. Input 4-20 mA signal only. The temperature control should be in Mode 6. (See 3.12.1)

Analog Output – Boiler output 0-10VDC, indicating approx firing rate/modulation percentage of the burner.

3.5 COMBUSTION AIR

Combustion air must be free from dust, lint, etc. The presence of such materials in the air supplied to the burner could cause nuisance "Low Air" shut-downs or premature burner failure. The boiler should not be operated during construction while the possibility of drywall dust, demolition dust, etc. exists.

Provisions for combustion and ventilation air must be in accordance with the National Fuel Gas Code, ANSI Z223.1, Section 8.3, latest edition, or applicable provisions of the local building codes. The formula is "1 sq. in. per 1,000 Btu/hr of gas input not less than 100 sq. in." The location shall be "neither more than 18 inches, nor less than 6 inches above the floor level."

In Canada, combustion air openings shall comply with CSA B149.

The boiler room shall be provided with two openings to ensure adequate combustion air and proper ventilation. One opening should be 6 to 12 inches above the floor and the other 6 to 12 inches below the ceiling, preferably on opposite walls. The size of each opening is determined by whether air is taken from inside or outside the building. In Canada, ventilation air openings shall be at least 10% of

the cross sectional area required for combustion air, but not less than 10 square inches. It is to be located at the highest practical point communicating with outdoors.

If air is taken directly from outside the building, each opening should have a net free area of 1 square inch for each 4,000 Btu per hour of total boiler input. For instance, 300 square inches (2-1/12 square feet) are required for 1,200,000 Btu per hour input.

When air is taken from the outdoors through a vertical duct, 1 square inch per 4,000 Btu per hour is required. If a horizontal duct is used, 1 square inch per 2,000 Btu per hour is required, i.e., 600 square inches for 1,200,000 Btu per hour input.

If air is taken from another interior space, each opening should have a net free area of 1 square inch for each 1,000 Btu per hour of boiler input (i.e. 1,200 square inches for a 1,200,000 Btu/Hr boiler.)

WARNING!

Under no circumstances shall the boiler room ever be under a negative pressure. Particular care should be taken when exhaust fans, compressors, air-handling units or other equipment may rob air from the boiler.

The combustion air supply must be completely free of chemical fumes which may be corrosive when burned in the boiler. Common chemicals which must be avoided are fluorocarbons and other halogenated compounds, most commonly present as refrigerants or solvents, such as freon, trichlorethylene, perchlorethylene, chlorine, etc. These chemicals, when burned, form acids which quickly attack the boiler tubes, tube sheets, flue collectors and the boiler vent. The result is improper combustion and premature boiler failure.

3.5.1 Sealed Combustion

The boilers are also certified for operation with a sealed combustion air system. Such a system employs a sealed combustion air intake duct leading from outdoors to the boilers. Air flow through the system is maintained by the fan inside the boiler assembly. Typical installations utilize through the



wall or through the roof routing for the supply of combustion air through a duct. It is important to locate the intake duct in such a way that it does not become blocked due to snow, ice, and other natural or man-made obstructions.

3.5.2 Intake Duct Materials and Sizes:

Material: PVC, CPVC (Schedule 40), single wall galvanized steel, or other suitable materials. The intake duct must be sized for a maximum pressure drop of 0.50 inches W.C. at 500 SCFM. The installation of a bird screen on the intake termination is recommended.

3.5.3 Sealing the Intake Duct

Proper sealing of the intake ductwork is necessary to prevent infiltration of air from conditioned spaces. Joints in PVC or CPVC must be cemented. For galvanized duct, wrap each joint and seam with adhesive aluminum tape.

3.5.4 Intake Duct Connection to Boiler

Connect the air supply duct to the collar on the back of the boiler. This collar is 7-7/8" OD. Fasten the duct to the collar with sheet metal screws at 90° angles. Wrap the joint with adhesive aluminum tape.

3.5.5 Intake/Exhaust Layout

A variety of configurations for the intake/exhaust may be used. **Refer to Section 3.6.5 for required clearances for all terminations.** The inlet and/or exhaust may be routed through the building sidewall and/or the roof. To prevent the possible recirculation of flue gases, the vent designer must take into consideration such things as prevailing winds, eddy zones, building configurations, etc. P-K cannot be responsible for the effects such adverse conditions may have on the operation of the boilers. Dimensions specified in this document are minimum clearances, and may or may not be sufficient for conditions at a specific job site.

3.6 VENTING (STACK)

This boiler requires a special vent system. **This boiler is not certified for use with Type "B" vent.**

This boiler is a **Category IV appliance** as defined in ANSI Z21.13/CSA 4.9, latest edition. The vent material must be listed Category IV vent pipe (316L or AL29-4C Stainless Steel) and comply with UL 1738 or UL 103. In Canada it must comply with ULC-636. The exhaust vent can be run horizontally or vertically.

Vent installations shall be in accordance with the National Fuel Gas Code, ANSI Z223.1, Part 10 or CSA B.149 code, or applicable provisions of the local building codes.

The venting system and the horizontal portions of the venting system shall be supported to prevent sagging.

The vent must be sized according to the vent manufacturer's recommendations. Consult your vent supplier for correct sizing and structural support requirements. Design calculations should be based on a back pressure of 1.0 inches w.c. frictional resistance in the vent with a stack temperature of 325° F (gross) and a CO₂ level of 8.5% (natural gas) or 9.9% (propane). These values are to be used for vent sizing calculations. The maximum certified back pressure allowable is 2.0 inches w.c. frictional resistance.

The boiler has an 8" OD connection for the vent. This connection may be reduced to 6" diameter provided the above backpressure conditions are met. A reducer is available from the factory for this purpose. Additional care must be used with sidewall venting as the exhaust velocity is high and the exhaust gas plume may extend significantly beyond the termination.

In addition to the information provided in this manual, visit the Gas Appliance Manufacturers Association's (GAMA) web site (www.gamanet.org) for a series of flash videos explaining the proper selection and installation of venting systems for gas appliances.



3.6.1 Venting Components

The connection from the boiler to the vent should be made using an adapter that is designed to fit the OD of the boiler outlet. The vent manufacturer's adapter must be sealed to the boiler outlet with sealant listed for use with the vent material. The first turn from horizontal to vertical should be made with a tee. A tee cover with a condensate drain shall be provided at the bottom of the tee. The condensate drain line from the boiler must be connected to the stack drain upstream of the stack trap using stainless steel tubing or piping. The stack trap shall have a minimum height of 4 inches. The condensate must be routed to a suitable drain that complies with all local codes.

WARNING! The boiler condensate drain line can get as hot as the stack. This may be up to 400°F. This line should be insulated to prevent thermal injury or burns.

WARNING! Do NOT use copper or plastic for the boiler condensate line, as these may fail and allow exhaust gas to leak into the room.

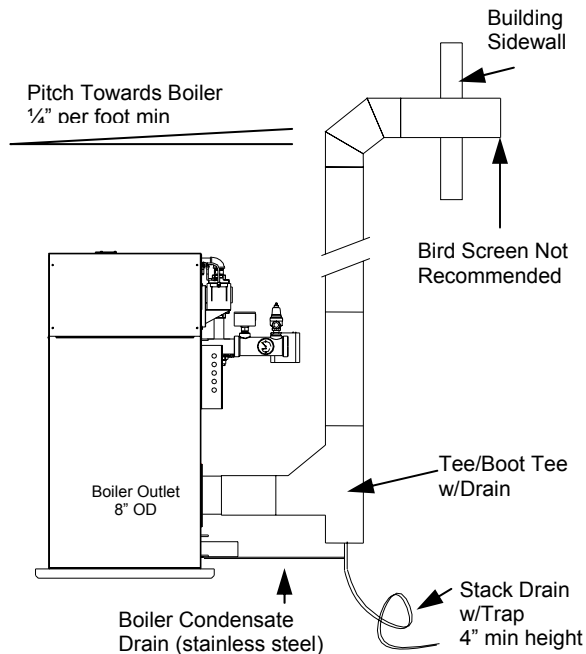

3.6.2 Barometric Damper

WARNING!
Do not use a barometric damper with this boiler. (This is a positive pressure system; combustion gas may leak into the room.)

3.6.3 Automatic Vent Damper

WARNING!
This equipment **MUST NOT** be used with an automatic vent damper.

3.6.4 Flue Connection

The connection from the boiler to the vent should be as direct as possible and the upward slope of any horizontal breaching should be at least 1/4 inch per linear foot. Provisions must be made for supports to prevent contact of the vent with combustible surfaces.

This boiler operates under a positive vent pressure. Do not connect any portion of the vent system of this boiler into a vent system operating under natural draft.

Notice: Make sure that the weight of the vent is **not supported** by the boiler vent collar. The collar is not designed to support the weight of the vent. Structural support and spacing from combustible surfaces must be in accordance with the vent manufacturer's requirements.

3.6.5 Clearances

Provide clearances between combustion air intake, exhaust vent, roof and window and snow line as shown in the following diagrams. The exhaust vent termination must not be less than 7 feet above grade in accordance with ANSI Z221 (NFPA 54), section 10.3.4.6, 2002 edition. The exhaust may not be vented directly above a public walkway per section 10.8.4 of the above standard. It must also have a minimum 6 foot horizontal and 6 foot vertical clearance (above or below) any electric meters, gas



meters, regulators, or relief equipment. See the diagrams on this page to further illustrate clearance requirements.

WARNING!
Do not locate intake or exhaust terminations directly above a walkway; dripping of condensation can cause icing of the walking surface.

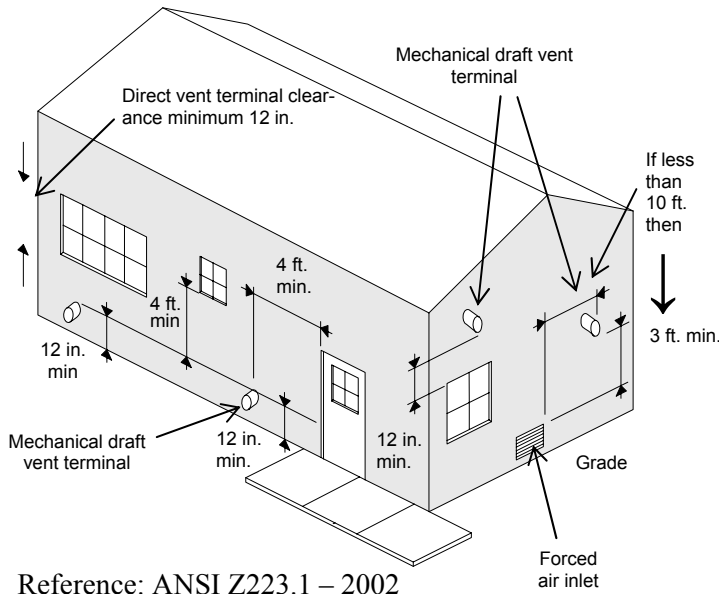

Reference: ANSI Z223.1 – 2002

Air Inlet and Venting Installations

3.6.6 Vent Terminations

P-K does not recommend the use of a vent cap. A screen termination is not recommended due to the possibility of ice formation on the screen. Rain is actually beneficial to the vent internals.

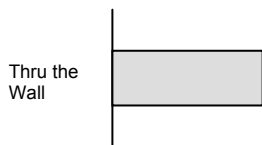
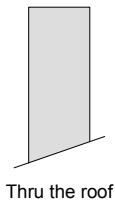

The minimum vent height should extend at least 3 feet above the roof, or at least 2 feet above the highest part of any structure within 10 feet of the vent.

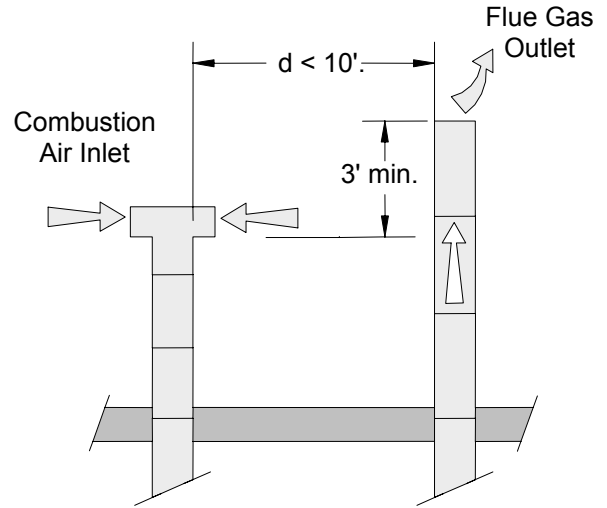

If the exhaust vent terminates within 10 ft. horizontally of the air inlet, the exhaust vent must be at least 3 ft. above the inlet. Dimensions listed above and those illustrated are minimum, and may or may not be sufficient for conditions at a specific job site.

To prevent the possible re-circulation of flue gases, the vent designer must take into consideration such things as prevailing winds, eddy zones, building configurations, etc. P-K cannot be responsible for the effects such adverse conditions may have on the operation of the boilers. It is important to locate the exhaust duct in such a way that it does not become blocked due to snow, ice, and other natural or man-made obstructions.



3.6.7 Venting for Multiple Boilers

The venting instructions in this manual apply to a **single** boiler.

Venting systems for multiple boilers must be designed by qualified professionals and verified by the vent manufacturer. The venting system must prevent backflow of exhaust gas through idle boilers.

Vent Installation Details

Installation must conform to the vent manufacturer's instructions in all respects including joining, clearances, fastening, fire-stopping, and other matters. The gaskets in Category IV venting are important, as they seal the positive pressure exhaust within the vent. Be sure to assemble the vent such that the gaskets make a positive seal at every joint.

Vent ductwork may be run vertically, or horizontally if so certified by the vent manufacturer. Vent ductwork must be supported according to the vent manufacturer's instructions.

3.6.8 Removing an Existing Boiler

When an existing boiler is removed from a common venting system, the common venting system is likely to be too large for proper venting of the appliances remaining connected to it.

At the time of removal of an existing boiler, while the other appliances remaining connected to the common venting system are not in operation, the following steps should be followed with each appliance remaining connected to the common venting system placed in operation:

1. Seal any unused openings in the common venting system.
2. Visually inspect the venting system for proper size and horizontal pitch and determine that there is no blockage or restriction, leakage, corrosion or other deficiency which could cause an unsafe condition.

3. Insofar as is practical, close all building doors and windows and all doors between the space in which the appliances remaining connected to the common venting system are located and other spaces of the building. Turn on clothes dryers and any appliances not connected to the common venting system. Turn on any exhaust fans, such as range hoods and bathroom exhausts, so they will operate at maximum speed. Do not operate a summer exhaust fan. Close fireplace dampers.
4. Place the appliance being inspected in operation. Follow the lighting instructions. Adjust the thermostat so that the appliance will operate continuously.
5. Test for spillage at the draft hood relief opening after 5 minutes of main burner operation. Use the flame of a match or candle or smoke from a cigarette, cigar or pipe.
6. After it has been determined that each appliance remaining connected to the common venting system properly vents when tested as outlined above, return doors, windows, exhaust fans, fireplace dampers and any other gas-burning appliance to their previous conditions of use.

Any improper operation of the common venting system should be corrected so the installation conforms with the National Fuel Gas Code, ANSI Z223.1 and CSA B149 Installation Code. When resizing any portion of the common venting system, the common vent system should be resized to approach the minimum size as determined using the appropriate tables.



3.7 GAS PIPING

Before making the gas hook-up, make sure the boiler is being supplied with the type of fuel shown on the boiler nameplate.

The boiler must be installed such that the gas system components are protected from water (dripping, spraying, rain, etc.) during appliance operation and service (circulator replacement, control replacement, etc.)

The boiler is factory fire-tested and adjusted for proper combustion with a natural gas supply pressure of 7 inches W.C. Typical supply gas pressure is 7 inches W.C. for natural gas (11 inches W.C. for propane). The gas train components are certified to handle a maximum inlet pressure of 14 inches W.C. (1/2 psig.). If the available gas pressure exceeds 14 inches W.C., a suitable additional intermediate gas pressure regulator of the "lock up" type must be provided to reduce the pressure to less than 14 inches W.C.

The minimum allowable gas pressure for proper operation of the unit is dependent on the vent resistance at high fire. The following chart details the minimum gas pressure allowed based on the vent frictional resistance.

For Natural Gas:

If:	Then:
Vent <1" W.C.	Min Gas Pressure = 4" W.C.
Vent >1" W.C.	Min Gas Pressure = 5" W.C.

For Propane, a minimum of 7 inches W.C. inlet gas pressure is required.

WARNING!

All threaded connections must be made using a pipe compound that is certified resistant to the action of liquefied petroleum gases. **Do not use Teflon tape on gas line threads.**

Notice: Piping must be installed such that no piping stresses are transmitted to the boiler. The boiler **shall not** be used as a pipe anchor.

The boiler and all gas piping connections should be pressure-tested and must be checked for leaks before being placed into service. Test with compressed air or inert gas if possible.

The boiler must be **disconnected** at the boiler manual shutoff valve (located at the end of the supplied gas train) from the gas supply piping system during any pressure testing of the system at pressures in excess of 1/2 psig (14 inch W.C.).

Some leak test solutions, including soap and water, may cause corrosion. These solutions should be rinsed off with water after testing.

RECOMMENDED GAS PIPING INSTALLATION

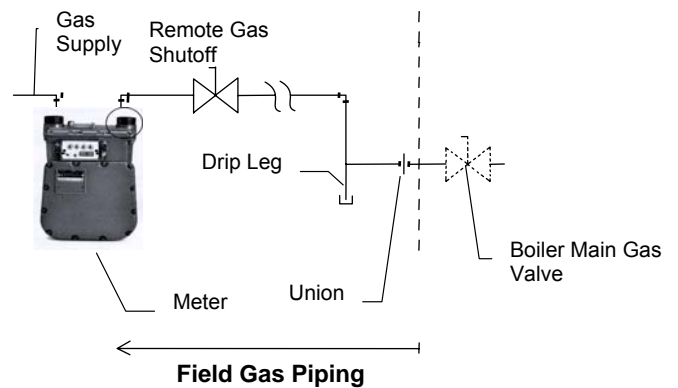

Notice: A sediment trap (drip leg) and a union connection should be installed upstream of the primary manual shutoff valve on the boiler. Gas piping should be installed in accordance with National Fuel Gas Code, ANSI Z223.1, latest edition, and any other local codes which may apply. In Canada, please refer to CSA-B.149.



Pipe Capacity for Natural Gas

Notice: See Pipe Capacity for Natural Gas chart for required pipe size, based on overall length of pipe from meter plus equivalent length of all fittings. Approximate sizing may be based on 1 cubic foot of natural gas per 1,000 Btu per hour input, i.e., 500,000 Btu per hour requires about 500 cubic feet per hour. (See "Typical Boiler Operating Conditions," Section 4.3, for more information.)

Table with 11 columns: Nominal Iron Pipe Size (Inches), Internal Diameter (Inches), Equivalent Pipe Length (90° Ell (Feet), Tee (Feet)), and Maximum Capacity in Cubic Feet of Natural Gas per Hour (Pressure Drop of 0.5 inch Water Column/Equivalent Length of Pipe (in feet) with sub-columns for 20, 40, 60, 80, 100, 150, 200).

3.8 BOILER WATER PIPING

3.8.1 Piping Design

Water Flow in System

Ideal operation of the MODU-FIRE® FORCED-DRAFT boiler would consist of a 20° F temperature differential across the heat exchanger at high fire. Insufficient flow may result in excessive short cycling of the boiler and eventual damage or premature failure of the equipment.

Notice: The closing of the flow switch does not prove that flow is adequate. It only indicates that some flow is present. Proper flow rates are 90-150 gpm for N/D1500MFD and 120-150 gpm for N/D2000MFD boilers.

Minimum Return Water Temperature should be greater than 130° F to avoid problems of condensation on the outside of the heat exchanger or in the flue passages.

Proper flow rates and return water temperature may be achieved through a combination of primary and secondary flow loops. Multiple zones and pumps may result in different flow rates at different times. Consideration must be given to all possible conditions and their consequences.

Piping with Refrigeration Machines

When used with a refrigeration system, the boiler shall be installed so that chilled medium is piped in parallel with the boiler. Valves should be installed to prevent chilled water from entering the boiler when the system is operated in the cooling mode.

Piping with Air Handling Units

The boiler piping system of a hot water heating boiler connected to heating coils located in air handling units, where they may be exposed to refrigerated air circulation, must be equipped with flow control valves or other automatic means to prevent gravity circulation of the boiler water during the cooling cycle.



3.8.2 Boiler Water Connections

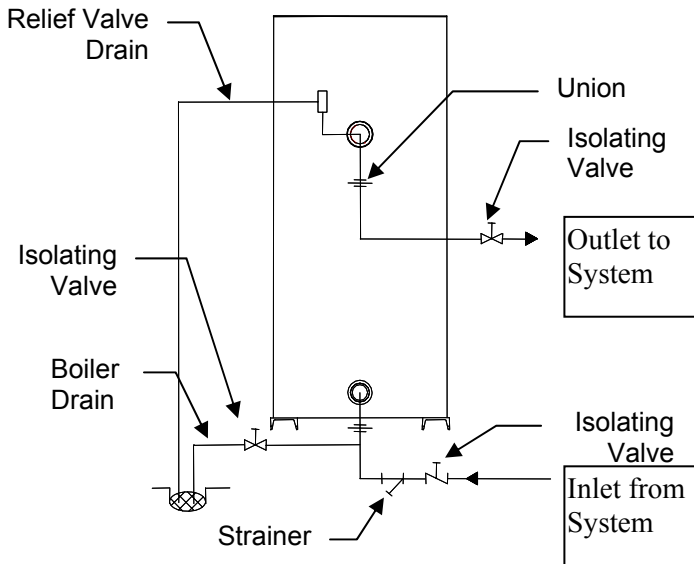

Boiler Water Connections

Make water connections as the application warrants, or at a minimum, as shown, but always in compliance with the local requirements.

Notice: Pipe unions and isolating valves must be installed in both water connections for ease of service.

The bottom connection to the boiler is the INLET and must be used for the return from the system.

The top connection to the boiler is the OUTLET and must be connected as the supply to the system.

Piping must be installed such that no piping stresses are transmitted to the boiler. The boiler **shall not** be used as a pipe anchor.

3.8.3 Boiler Water Piping by Installer

Strainer

To avoid possible contamination of the boiler with dirt, rust or sediment from the system, a strainer near the boiler inlet is strongly recommended. Even new systems may contain sufficient foreign material to eventually reduce the performance of the heat

exchanger. Adequate circulation of good clean water is essential to maximum efficiency and long life of the boiler.

Relief Valve and Piping

Each boiler is supplied with a pressure-relief valve sized in accordance with ASME requirements. The relief valve must be piped to a suitable drain prior to placing the boiler into service and in a manner that prevents water spray from contacting any person. Reducing couplings or other restrictions are not permitted in the discharge line. **WARNING:** Do not plug or obstruct the discharge of the relief valve.

Low Water Cut-off

The boiler is furnished with a flow-switch-type low water cut-off as required by the ASME BPV Code, Section IV; no field piping is required. If the flow switch does not sense water flow, the boiler will shut down and a red indicator will be illuminated on the control panel.

Installation of an external low water cutoff or manual reset low-water switch may be required by certain codes or in certain installations. Consult your local code for details.

WARNING!

Never install a valve that can isolate the low water cut-off from the boiler.

Drain Valve and Piping

The boiler is not provided with external drain connections. A drain valve should be installed near the inlet (system return) connection to the boiler and piped to a suitable floor drain. The boiler can be completely drained through the bottom header by removing the flush plug in the bottom end plate.

This plug may also be used to flush accumulated sediment from the bottom of the boiler.

3.8.4 Flushing and Filling

Flushing the System

Before filling the boiler, flush the system to remove the debris. Clean and flush old piping thoroughly before installing the boiler as recommended by your water conditioning or chemical treatment supplier.



Under no circumstances should the hydronic system be flushed while the boiler is attached to the system since the debris or corrosion products could accumulate in the boiler and plug the boiler heat exchanger.

If the piping system attached to this unit will be chemically cleaned, the boiler must be disconnected from the system and a bypass installed so that the chemical cleaning solution does not circulate through the boiler.

Filling

To be sure that the boiler is not air-bound, open the pressure-relief valve located at the rear of the boiler. Leave the relief valve open until a steady flow of water is observed. Close the valve and finish filling the system.

3.8.5 Water Quality

The boiler is designed to operate in a closed-loop system using water or water/glycol only. As such, the system should be tight and not require make-up water. A high percentage of untreated make-up water can cause premature failure due to build up of scale. Such failure is not covered by warranty.

Scale can also reduce efficiency. For example, a scale thickness of 1/16 inch will result in a 12.5% loss of efficiency.

The water quality should be within the guidelines established by the American Boiler Manufacturers Association, as follows:

- Total solids: 2,500 ppm
- Total alkalinity: 500 ppm
- Total hardness: 150 ppm

In addition, the amount of oils, fats, grease, and other organic matter should be limited to 10 ppm.

Consult your water conditioning or chemical treatment supplier for analysis and recommendations. Employing a conscientious and competently administered program with emphasis on good maintenance practices as outlined by your water treatment specialist is recommended.

If water/glycol is to be used in the system, the customer should perform a hazard analysis to determine proper use and disposal.

3.9 BURNER AND IGNITION SYSTEM

3.9.1 Inspection

Inspect the burners to be sure nothing was damaged or knocked loose during shipment. Inspect the main gas train and ignition assembly to be sure they were not damaged during shipment or installation.

Check all gas unions for tightness.

3.10 PRE-START CHECK LIST

Before attempting to start the boiler, make sure the following items have been completed.

1. Flue gas from the boiler is properly vented. (See section 3.6)
2. Gas connection has been made, pressure tested for leakage, and the line purged of air. (See section 3.7)
3. Water connections are complete, and the boiler and system have been filled and purged of air. (See section 3.8)
4. The boiler must be connected to a 230 volt / 60 Hz / 1 Ph power source with proper polarity, a dedicated machinery ground, and provided with a disconnect having adequate overload protection. (See section 3.4)
5. Combustion air openings are not obstructed in any way and have adequate capacity. (See section 3.5)
6. The boiler is located with the proper clearances as shown in this manual. (See Section 3.3.3)
7. Relief valves have been properly piped to floor drains. (See section 3.8.3)
8. There are no flammable liquids, materials or hazardous fumes present in the environment.
9. Remove/account for all tools and parts.
10. All panels and parts should be properly installed.



3.11 SAFETY CHECKS

The following checks of safety systems must be made before putting the boiler into normal operation.

Before firing the boiler refer to Sections 4.1 and 4.2 for information on the use of the controls, lighting, and shut-down procedures.

WARNING!

Never attempt to operate a boiler that has failed to pass all the safety checks described below.

WARNING!

After checking controls by manual adjustment, make sure they are always reset to their proper settings.

3.11.1 Test of Ignition Safety System

Test the ignition system safety shutoff as follows:

1. Remove the black plug/connector from the main gas valve (it is held on with a central screw).
2. With the main gas cock (inlet manual gas valve) open, the burner should be cycled on. After all the safety limits such as gas pressure, water flow and temperature are satisfied, the blower will run and pre-purge the boiler.
3. Once the purge is complete (30 seconds), the ignition transformer will be energized. There will be a 4 second trial for ignition period. During this period, indicator lights on the flame safeguard (pilot and main) will illuminate indicating the boiler is attempting to light.
4. The main gas valve will not open because there is no power to the valve due to the disconnected wires. Hence, no flame will be established and the flame safeguard will not receive a flame signal from the UV scanner.
5. After 4 seconds, the flame safeguard programmer will assume a "Flame Failure" condition and go to a "lockout" mode. Lockout will require manual reset of the flame safeguard.

After completing this test, turn off the boiler and reconnect the wires to the main gas valve.

3.11.2 Test of Low Water Cut-off

The boiler is furnished with a flow-switch-type low water cut-off in the outlet nozzle. Test as follows:

1. Turn boiler and then system pump off.
2. Turn boiler back on.
3. Red "Water Flow" light should illuminate after a call for heat from the temperature control. The boiler should not start until the pump is started.

Perform appropriate tests on any external probe-type low water cut-off.

3.11.3 Test of Limit Controls

Fire the boiler and test the high limit control as follows:

With the main burner operating, turn down the temperature setting on the "high-limit" thermostat until the main burner shuts off (the green "Heat" indicator will go out). The high-limit switch must be manually reset after testing. A similar check should also be made for the operating temperature control (see Section 3.12 for instructions on setting this control). After completion of these tests, re-adjust thermostats to desired operating temperature and set high-limit temperature, typically 20° F above operating temperature.

3.11.4 Test of Low Gas Pressure Switch

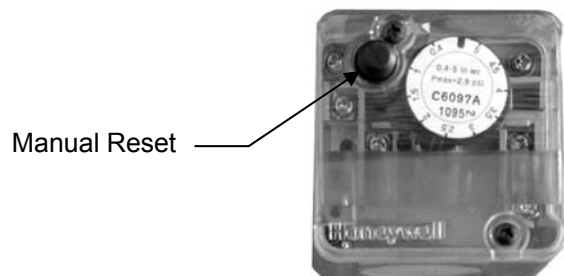

Gas Pressure Switch



The boiler is furnished with a low gas pressure switch. The operation of this switch must be checked by slowly closing the main gas cock while the burner is operating. The switch should shut down the main burner. When the gas pressure switch opens, the "Gas Press." indicator will light. Upon reopening the main gas cock, the "Gas Press." indicator should remain on until the low gas pressure switch is manually reset.

3.11.5 Test of High Gas Pressure Switch

The boiler is furnished with a high gas pressure switch. The operation of this switch must be checked by closing the downstream main gas cock, and starting the boiler. Once the trial for ignition period is reached, the main gas valve will open, pressurizing the line. This will trip the high gas pressure switch.

The high gas pressure switch must be manually reset after it trips.

3.12 INITIAL ADJUSTMENTS

3.12.1 Configuring the Temperature Control

The boiler is equipped with a modulating temperature control to maintain the desired outlet water temperature. This control has various modes of operation which are listed below.

Definitions:

The following items are common to Modes 1 thru 5. They are not required for Mode 6 – the mode for external boiler control.

- MODE:** Operating mode of the boiler.
- BOIL TARGET:** Target temperature that the boiler is trying to maintain.
- BOIL MAX:** Highest outlet water temperature that the control is allowed to use as a target temperature.
- BOIL MIN:** Lowest outlet water temperature that the control is allowed to use as a target temperature.

- FIRE DELAY:** Factory Set (Low fire hold)
- BOIL MASS:** Factory Set **DO NOT MODIFY THIS ITEM**
- DIFF:** The operating differential of the boiler. The boiler outlet water temperature is allowed to rise above the BOIL TARGET temperature by 1/2 of this differential before the boiler shuts off.
- MOTOR SPEED:** Factory Set **DO NOT MODIFY THIS ITEM**
- START Modulation:** Factory Set **DO NOT MODIFY THIS ITEM**
- MIN Modulation:** Factory Set **DO NOT MODIFY THIS ITEM**
- PUMP DLY:** Sets the operating time of the pump once the boiler is turned off.
- UNITS:** Selects the temperature units to be displayed (°F or °C).

For example, if the boiler target temperature is set to 160°F and the differential is set to 10°F, on temperature rise, the boiler will shut off at 165°F. Once the boiler shuts off, it will not come on again until the temperature falls to 155°F.

Operating Modes:

- Mode 1 – setpoint operation using parallel piping. The boiler outlet water temperature is controlled to the boiler target setpoint.
- Mode 2 – setpoint operation using primary/secondary piping. The control modulates the boiler to satisfy a remote header sensor. The boiler is turned off based on boiler max and boiler differential.



- Mode 3 – dedicated DHW operation using parallel piping. A call for heat is determined by the DHW sensor. The boiler outlet water is controlled to the boiler target temperature.
- Mode 4 – outdoor reset and reset override operation using parallel piping. The boiler is operated as in Mode 1. However the target temperature is based on outdoor reset. The outdoor reset temperature can be remotely overridden.
- Mode 5 – outdoor reset and reset override operation using primary/secondary piping. The boiler is operated as in Mode 2. However, the target temperature is based on outdoor reset. The outdoor reset temperature can be remotely overridden.
- Mode 6 – This mode is used for remote control mode. The Boil Max setting is the boiler shut-down temperature.

Operation:

The Boiler Temperature Control uses a Liquid Crystal Display (LCD) as a method of supplying information. The LCD is used to setup and monitor system operation by means of three push buttons (Scroll, ▲, ▼). Scroll advances the display, while ▲, ▼ are used in the adjust menu.



All items displayed by the control are organized into two menus, the view menu and the adjust menu. The active menu is displayed in the upper right hand

side of the display in the menu field. The default menu is the view menu.

When the temperature control is powered up, the control turns on all segments in the display for 2 seconds, then the software version is displayed for 2 seconds. At the end of that 4 second period, the control enters the normal operating mode and “VIEW” is displayed. Pressing the scroll button “scrolls” through the displayed values in the “VIEW” menu.

To make an adjustment to a setting in the control, begin by selecting the “ADJUST” menu. To change from the view menu to the adjust menu, simultaneously press and hold all three buttons for 1 second. The menu name, “ADJUST” will be displayed in the menu field. The menu will automatically revert back to the view menu after 20 seconds of keyboard inactivity.

To make adjustments, scroll to the desired item using the scroll button. Finally, use the ▲ or ▼ button to make the adjustment.

In the absence of other information, the following should be used as default item settings:

ITEM	DEFAULT
MODE	1
BOIL TARGET	180°F
BOIL MAX	210°F
BOIL MIN	140°F
FIRE DELAY	1:30
BOIL MASS	1
DIFF	20°F
MOTOR SPEED	20
START MODULATION	0
MIN MODULATION	0
PUMP DLY	5:00
UNITS	°F



3.12.2 Air Flow Adjustment

There are no required start-up or field adjustments for air flow control. DO NOT attempt to change any parameters in the blower speed control (inverter). The Modu-Fire FD uses a micro-processor controlled variable frequency inverter to control the speed of the blower. The air flow is set at the factory. Should an error occur during operation, the inverter will automatically reset after 30 seconds. If the error recurs, log the flashing error code and call for authorized service.

3.12.3 Fuel/Air Ratio Adjustment

The fuel/air ratio is controlled by the automatic air gas ratio valve. This valve is adjusted at the factory to give 5.5-6% O₂ at high fire and 7.5-7.9% O₂ at low fire in the exhaust gas. However, the fuel/air ratio should be checked using a combustion analyzer at start-up to verify that the combustion is proper. Remove the vent plug and place the analyzer probe in the vent as shown. Be sure to replace the plug after combustion has been set.

Start the boiler. Place the probe of a combustion gas analyzer in the stack as shown. Using the toggle switch on the boiler control panel, place the boiler in High Fire. If the % O₂ is not within the range above, the gas valve should be adjusted.

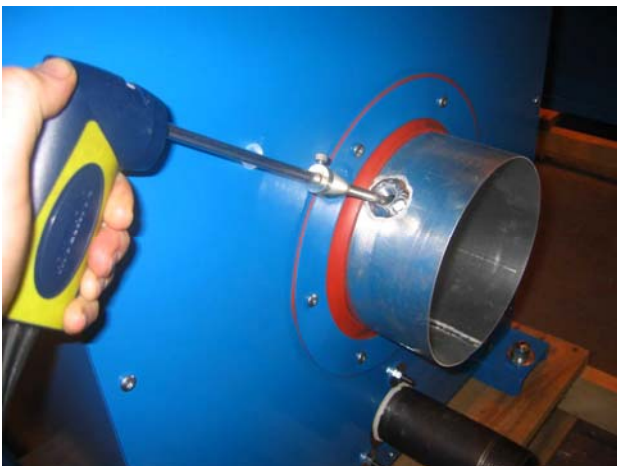

To adjust the gas valve on hi fire, turn the top screw “V” clockwise to reduce the % O₂ or turn it counterclockwise to raise the % O₂. Once high fire is adjusted, place the boiler in low fire using the toggle switch and adjust the % O₂ if necessary, by turning the bottom screw “N” clockwise to reduce the % O₂ and counterclockwise to increase the % O₂.

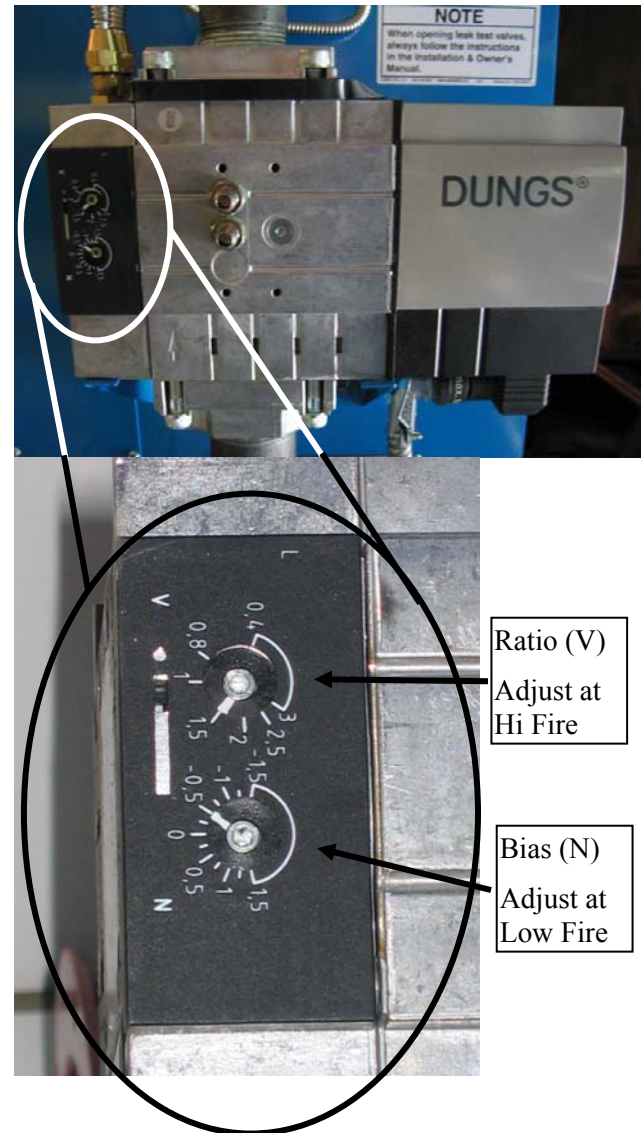



4.0 OPERATION

4.1 GENERAL

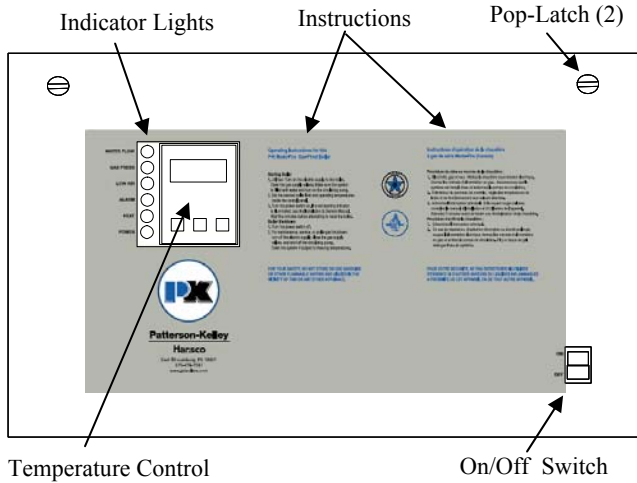

The front of the control panel shows Operating Instructions and a series of illuminated indicator lights and the temperature control. The boiler operating controls are accessed by turning the pop-latches ¼ turn, and opening the front cover.

4.1.1 Normal Operation

Under normal operating circumstances, this boiler functions as a fully automatic appliance. The automatic control senses the water outlet temperature and fires the boiler when heat is needed by the system. Additionally this boiler may function as part of an integrated building management system.

4.2 LIGHTING AND SHUT-DOWN PROCEDURES

WARNING!

Do not use this boiler if any part has been under water. Immediately call factory-trained personnel to inspect the boiler and replace any part of the control system and any gas control which has been exposed to water.

Interior Control Panel
(See 6.1.2 for details)

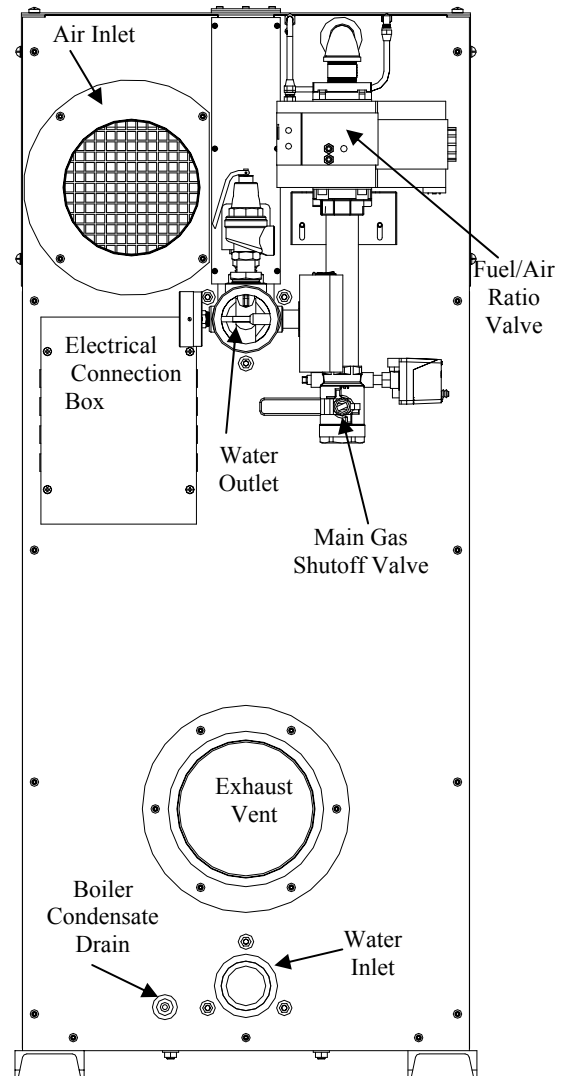
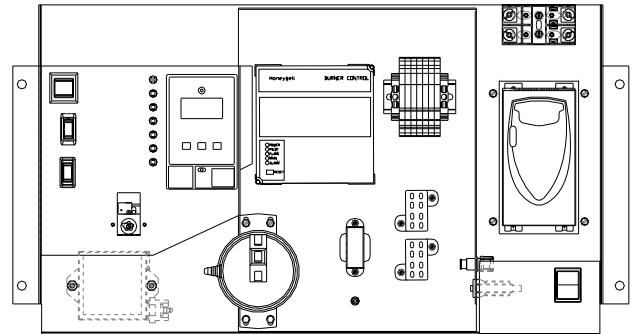

Boiler Rear Components



4.2.1 Initial Lighting Procedures

1. Utilities: Turn on electrical supply to the boiler. Open the gas supply valves. Make sure the system is filled with water and turn on the circulation pump.
2. Reset Switches: Press the reset button on both the high gas and low gas pressure switches if the gas supply had previously been turned off. Press the control reset button after a safety lock-out.
3. Set the desired high temperature limit and operating temperature.
4. Turn on the power switch. If a red warning light indicator is illuminated, see Section 5.6 of this manual to troubleshoot the problem and take the necessary corrective action before proceeding.

4.2.2 Normal Shut Off Procedures

1. Place the on/off switch in the off position.
2. Close all manual gas valves.
3. Turn off electrical power.

4.2.3 Emergency Shut Off Procedures

The main gas cock should be closed immediately. If overheating occurs or the gas supply fails to shut off, do not turn off or disconnect the electrical supply to the pump. Instead, shut off the gas supply at a location external to the boiler.

4.3 TYPICAL BOILER OPERATING CONDITIONS

Model No.	Input Rating (Btu/hr)	Natural Gas (1030 BTU/cu. Ft)	
		Gas Rate (scfh)	Output Capacity (Btu/hr)
1500	1,500,000	1,456	1,275,000
2000	2,000,000	1,942	1,700,000



5.0 MAINTENANCE

WARNING!
Installation and service must be performed by a qualified and knowledgeable individual, such as a PK representative, qualified installer, service agency, or gas supplier.

WARNING!
Proper lockout / tagout procedures must be employed when servicing this unit.

Hazard analysis should be performed by end user to insure safety of their employees and/or service technicians.

All weekly, monthly and annual maintenance checks should be performed by qualified and knowledgeable personnel.

5.1 MAINTENANCE AND INSPECTION SCHEDULE

WARNING!
Label all wires prior to disconnection when servicing controls. Wiring errors can cause improper and dangerous operation.

Verify proper operation after servicing.

5.1.1 Daily

Observe operating temperature and general conditions. Make sure that the flow of combustion and ventilating air to the boiler is not obstructed. Determine the cause of any illuminated red indicators, unusual noises or operating conditions and make the necessary corrections.

WARNING!
Check daily to be sure that the boiler area is free and clear of any combustible materials, including flammable vapors and liquids.

5.1.2 Weekly

Observe the conditions of the main flame. A normal high fire flame shows an orange screen with a blue halo. In Low fire the burner should display a reddish orange glow.

Correct air adjustment is essential for the efficient operation of this boiler. If an adjustment to the combustion is necessary, the flue gas composition should be checked with a carbon dioxide (CO₂) or oxygen (O₂) analyzer to set conditions. Refer to Section 3.12.2 and 3.12.3.

5.1.3 Monthly

1. Test flame detection by voltage reading at the control programmer.
2. Test high-limit control by reducing setting below the operating temperature. Burner should shut off. After readjusting the thermostat, press the button to reset the switch.
3. Test operating temperature control by reducing temperature setting as necessary to check burner operation.
4. Check flue gas temperature at outlet. If there is a temperature increase over previous readings, the probable cause is soot or water-scale build-up on the tubes.
5. Test the water flow switch by trying to restart boiler with the system pump off. The boiler should not operate and the red water flow indicator should light.
6. Test low gas pressure switch and high gas pressure switch utilizing the procedure in sections 3.11.4 & 3.11.5. The boiler should fail to start and the red gas pressure indicator should light.
7. Inspect and clean the inlet screen of any accumulated dust or lint.
8. The relief valve should be tested as per manufacturers instructions or every two months by lifting the lever for 5 seconds and allowing the valve to snap shut. Please see the manufacturer's recommendations on the relief valve tag.



5.1.4 Annually

In addition to the recommended monthly service:

1. Check burner and wash off (do not scrub or use wire brush) any soot or foreign material that may have accumulated. See Section 5.2 on "Cleaning the Burner." Check the burner and its parts. If there is evidence of deterioration or corrosion, replace immediately.
2. Inspect combustion chamber. To access the heat exchanger, remove the front door and the front inner wrapper. Note any signs of deterioration. Examine the gasket and replace if necessary, using P-K gasket kit only.
3. Inspect and clean heat exchanger. Wash the copper tubes with water and non corrosive soap. Green scale on the tubes indicates that the boiler is condensing which is detrimental to boiler life. Perform corrective action as necessary.
4. Examine the venting system.
 - a. Check all joints and pipe connections for tightness.
 - b. Check vent for corrosion or deterioration. If any venting needs replacing, do so immediately.
5. Inspect heating system for other problems.
6. Perform combustion analysis and adjust if necessary (See 3.12.3).
7. Leak test gas valves. Leak Test must be performed only by qualified PK certified personnel, who have been trained in this procedure. This procedure is available on request from the PK Factory.

5.2 CLEANING THE BURNER

Burner Assembly

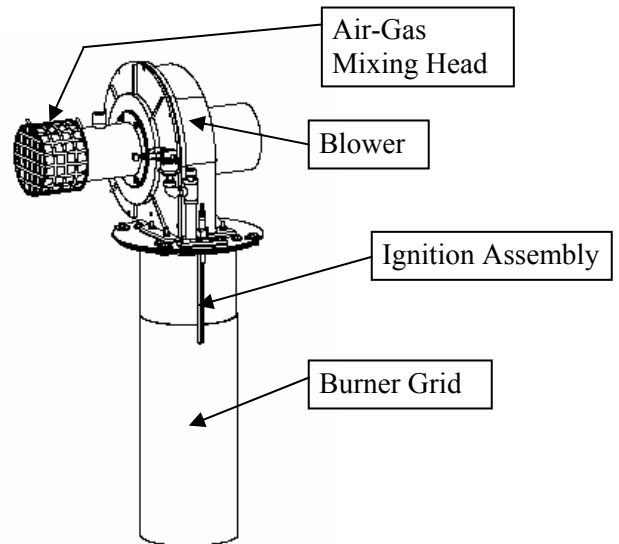

1. **WARNING!** Follow proper lockout / tagout procedures for the electrical, gas, and water connections. Use caution when lifting heavy parts.
2. Remove top and side covers from the boiler.
3. Disconnect the gas union, high gas pressure switch wires and the wire plug connector to the blower. Disconnect the UV scanner, ignition wire, ground wire and the wires to the back pressure switch.
5. Disconnect the air gas mixer sensing tubes. Note: these tubes are color coded and must be correctly reinstalled.
6. Remove the blower/air gas mixer assembly from the top of the burner.
7. Clean the blower vanes. Do not disassemble the blower motor or aluminum housing.
8. Remove the burner using the four hold down screws.
9. Check burner and wash off (do not scrub or use wire brush) any soot or foreign material that may have accumulated.



- 10. Check that gap between the electrode and the ground rod. It should be 1/8 inch (+1/16, -0). For Propane, the gap should be exactly 1/8".

The electrode height is not adjustable. If adjustment is necessary, only the ground rod should be adjusted. Check for cracking of the electrode. Do NOT overtighten the electrode.

- 11. Use a soft, clean cloth to remove accumulated contaminants from the UV detector/scanner glass envelope.

rectly. If adjustment is required, refer to section 3.12.3.

5.3 REMOVING THE HEAT EXCHANGER

WARNING!

Heat Exchanger is heavy and may cause injury if improperly handled. Removal of the heat exchanger should be performed only by knowledgeable and experienced personnel.

5.4 AFTER ALL REPAIRS OR MAINTENANCE

- 1. Follow "Pre-Start Check List" (Section 3.10) and all "Safety Checks" (Section 3.11).
- 2. Fire the Boiler and perform combustion check.
- 3. Adjust gas flow if necessary. (See "Gas Pressure Adjustment", Section 3.12.3)

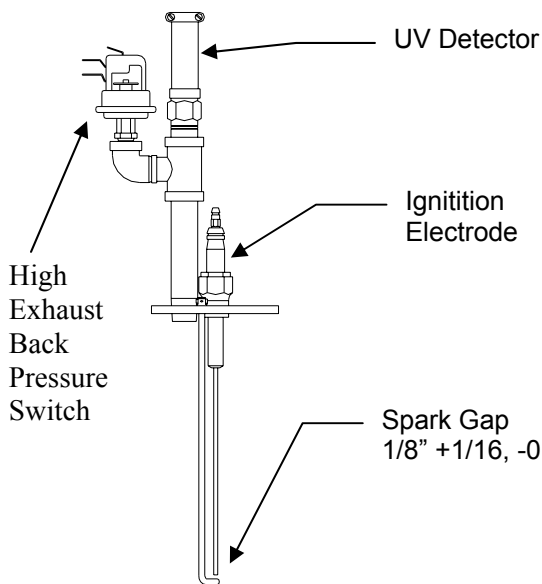

Ignition Assembly

- 12. Before re-installing the burner, check the cleanliness of the heat exchanger and the condition of the combustion chamber. If corrosion or leaks are noticed, please call for service.
- 13. Install the burner and blower assembly. Reconnect the green ground wire, ignition wire, high gas pressure switch wires, the wire plug to the blower, the two air gas mixer sensing tubes, the UV scanner, and wires to the back pressure switch. **Before starting the boiler make sure to reconnect and tighten the gas union!**
- 14. Reinstall all covers.
- 15. Fire Test the boiler and use a combustion analyzer to ensure that the fuel/air ratio is set cor-



5.5 SEQUENCE OF OPERATION

1. When the 230V/1Ph/60Hz fused disconnect is energized, there is power to the combustion blower speed control. When the On/Off (boiler power) switch is turned on, the power LED illuminates and power is provided to the flame safeguard control and the transformer for the temperature control. Power is also applied through the “start logic string” which is a series of normally closed switches, including water flow, gas pressure, high stack temp, high limit temperature, and operating temperature and finally into the flame safeguard programmer call for heat.
2. The water flow limit switch is made when there is water flow through the boiler and the red water flow light is off.
Notice: The closing of this switch does not prove that flow is adequate. It only indicates that some flow is present. Refer to Section 3.8 for proper flow rates.
3. When adequate gas pressure is available, the low gas pressure limit switch is closed. Manual reset is required following conditions resulting in low gas pressure.
4. When the temperature sensed by the high limit temperature control is below the set limit, the switch is closed. Manual reset is required following conditions exceeding high limit temperature.
5. When heat is required as indicated by the outlet water temperature, power is applied to Terminal 6 of the programmer, which initiates the burner ignition and operation sequence.
6. The programmer first energizes Terminal 4 which energizes relay 1. Normally open contacts of relay 1 close enabling the run forward terminal of the blower speed control. This drives the blower to its start speed. The air flow switch initially shows low air flow with the “LOW AIR” indicator. This indicator will remain on until sufficient air flow is sensed. If the fan speed is insufficient for proper purge, the air flow switch does not close, the red “low air” light remains illuminated and the combustion sequence does not go any farther.
7. Once sufficient air flow is indicated by the air flow switch, and if the combustion chamber back pressure is less than 4” w.c. indicating an obstruction free vent, terminal 7 of the combustion control is energized. This starts the 30 second purge of the combustion chamber.
8. After the 30 second purge, a 4-second “trial for ignition” period is initiated with Terminal, 8, 9 and 10 being energized. Terminal 10 of the combustion control powers the ignition transformer and Terminals 8, and 9 energize the main gas valve. The transformer output creates a spark at the igniter.
9. After the 4 second “trial for ignition” period, if a flame has been established, Terminal 10 of the combustion control is de-energized. Terminal 9 remains energized. Terminal 21 is energized, releasing the speed control to modulation. The temperature control modulates the fan speed to control the outlet water temperature and the gas control valve modulates the gas input proportional to the fan speed to maintain the desired combustion characteristics.
10. When the load is below the low fire rating of the boiler, the boiler will continue firing and the outlet water temperature will rise until it reaches the set point + 1/2 of the boiler differential setting. At this point the operating control contacts open, the combustion control is de-energized at Terminal 6 and the indicator for HEAT is turned off. This action also de-energizes Terminals 8, 9, and 21 thus closing the main gas control valve. The speed control continues to run the blower to post purge the combustion chamber.
11. When the return water temperature is reduced by the load on the system, the operating control switch will close again. The operating sequence will recycle to Step 5, provided the limits on water flow, gas pressure and high temperature are all met.



5.6 TROUBLESHOOTING

WARNING

If any “Manual Reset” limit device trips,
DO NOT
reset without
determining and correcting the cause.

(Manual Reset Limits include: Flame safeguard,
high or low gas pressure, high temperature limit,
stack temperature.)

Loss of Power

In the event of loss of power, the entire boiler system is de-energized, closing all automatic valves and halting all boiler operations. When power is restored the sequence of operation will resume at Step 5, provided that all the limits are satisfied.

Loss of Water Flow

When there is insufficient water flow to close the flow switch, the "Water Flow" indicator is illuminated, and burner operation is interrupted. When water flow is re-established, the sequence returns to Step 2, provided that the other limits are satisfied.

Gas Pressure

When the "Gas Press" indicator is illuminated, there has been either insufficient gas pressure or the gas pressure to the manifold is too high for safe and proper operation of the boiler. The power to terminal 6 on the combustion control will be interrupted, shutting down the burner.

If a gas-supply shutoff valve is closed for any reason, a low gas condition will result.

When gas pressure is restored, the "Gas Press" indicator will remain on and the boiler will remain locked out until the gas pressure switch is manually reset.

In the event of a high gas manifold pressure condition, the “Gas Press” indicator will illuminate indicating a potential air gas ratio control failure. This must be corrected by qualified service personnel before restarting the boiler.

Once the switch is reset, the sequence returns to Step 3, provided that the other limits are satisfied.

High Water Temperature

When the boiler water has exceeded both the operating and high-limit temperature, power to the programmer is interrupted. When the water temperature falls below the high-limit temperature, the boiler will remain locked out until the switch is manually reset. Once the switch is reset, the sequence returns to Step 4 to await heat demand provided that the other limits are satisfied.



Low Air

CAUTION The air switch has been factory set and should not be adjusted in the field.

The “Low Air” indicator illuminates if the air flow switch detects low air flow through the boiler.

An extended low air indication does not mean that the low air switch is defective.

- Check that blower is electrically connected to the inverter.
- Check that the burner is clean (refer to Section 5.2).
- Check for obstructions in the vent.
- Check for obstructions in the air inlet.

Vent Pressure

In the event of the vent having too much pressure, the High Exhaust Back Pressure Switch (HEBPS) will trip and shut down the boiler. This condition will automatically recycle, so the boiler will try to relight. The vent and heat exchanger should be checked for obstructions and cleaned.

Ignition Failure

In the event the flame is not detected by the UV scanner during the 4 second trial-for-ignition period (Step 9), the gas valve and spark ignition are de-energized. At this time a safety lockout occurs which de-energizes all outputs from the programmer except Terminal A, which is connected to the "Flame Failure" indicator. The Red alarm light will light up. A manual reset of the programmer (located inside the control panel) is required and the boiler power switch should be cycled off and on.

Flame Failure

In the event of a main flame failure during a firing period, the main gas control valve is de-energized and the programmer immediately goes into "lockout" mode. If flame failure occurs and the indicator is illuminated, the programmer must be manually reset.

All Limit Points Alarm (ALPA)

When there has been a call for heat for greater than 5 minutes and the burner has not advanced to main flame the all limit points alarm (ALPA) is triggered. This removes power to terminal 6 of the combustion control shutting down the burner. The ALARM relay (R7) on the front panel energizes, illuminating the amber LED. To reset the ALPA you must press and hold the red inverter reset button until the R7 indicator light goes out.



6.0 PARTS/TECHNICAL SUPPORT

Spare parts and replacement parts can be ordered from your local representative or Patterson-Kelley by calling (877) 728-5351. The fax number is (570) 476-7247. Refer to the parts list shown on the assembly drawing provided with this manual. Factory direct replacement parts must be used to ensure that the boiler operates correctly.

WARNING! Use of Non-Factory-Authorized replacement parts are not recommended for this equipment. All control components are engineered for safety and are designed to work in unison with each of the other components. Use of non-factory-authorized replacement parts would jeopardize the functionality of the safety features as well as the performance of the boiler.

Technical information is also available at the above number or at the Patterson-Kelly website www.pkboilers.com.

When ordering replacement parts please have the **model number** and **serial number** of your boiler available.

The model number should be either a 1500 or a 2000 with prefix and suffix letters. The serial number is an 11 digit number formatted as shown: FXXX-XX-XXXXX The first two characters are alpha characters indicating the cabinet size and the level of the unit. The remaining characters are all numeric indicating the week and year of manufacture and a unique 5 digit number.

6.1 SCHEMATIC DIAGRAMS

Typical schematic drawings are shown on the following pages. Drawings specific to your particular boiler can be supplied by your local P-K representative.



6.1.1 Wiring Schematic

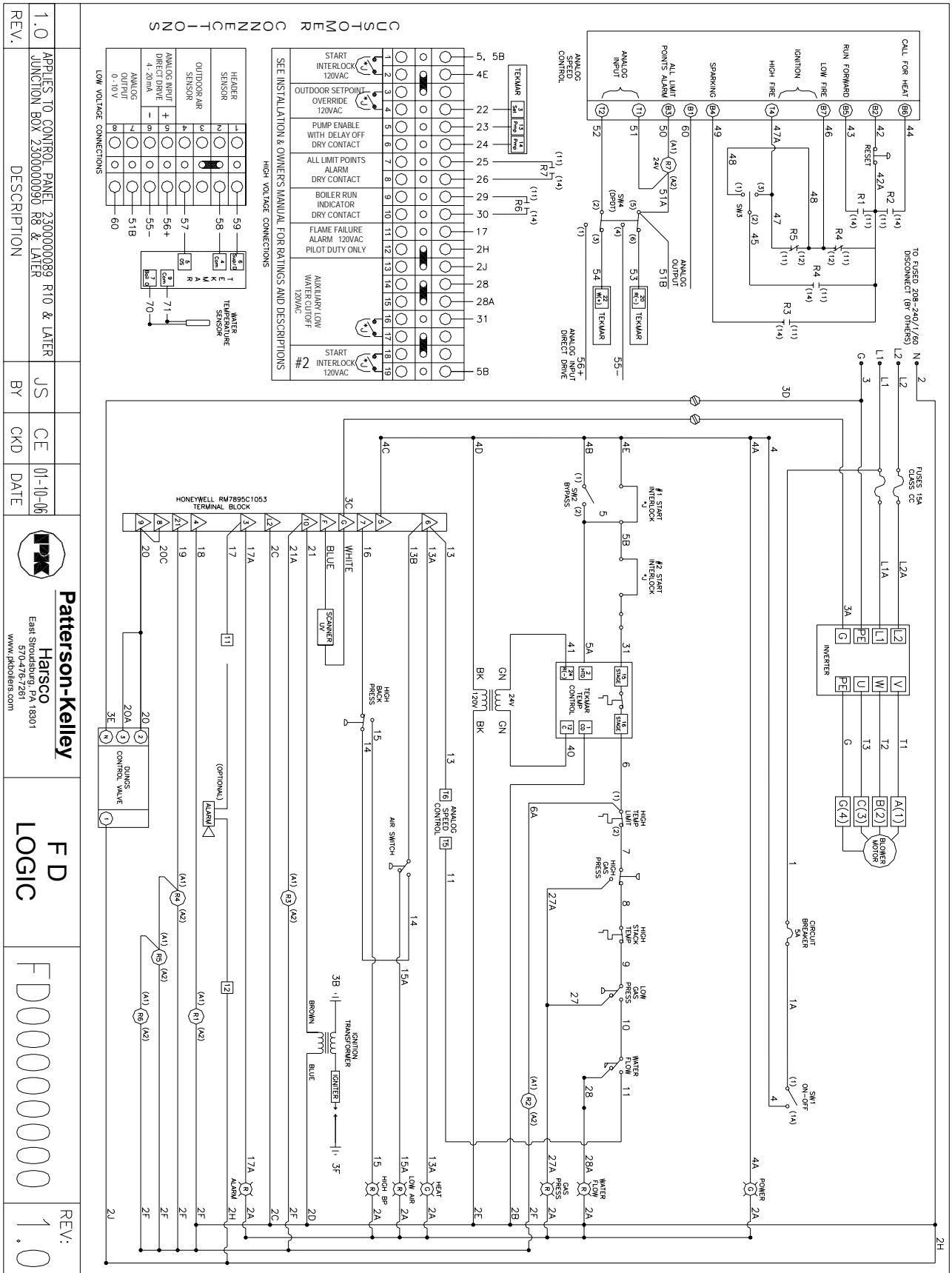

CONNECTIONS

1	2	3	4	5	6	7	8	9	10	11	12	13	14	15	16	17	18	19	20	21	22	23	24	25	26	27	28	29	30	31
○	○	○	○	○	○	○	○	○	○	○	○	○	○	○	○	○	○	○	○	○	○	○	○	○	○	○	○	○	○	○
○	○	○	○	○	○	○	○	○	○	○	○	○	○	○	○	○	○	○	○	○	○	○	○	○	○	○	○	○	○	○

LOW VOLTAGE CONNECTIONS

1	2	3	4	5	6	7	8	9	10	11	12	13	14	15	16	17	18	19	20	21	22	23	24	25	26	27	28	29	30	31
○	○	○	○	○	○	○	○	○	○	○	○	○	○	○	○	○	○	○	○	○	○	○	○	○	○	○	○	○	○	○

DESCRIPTION

1.0	APPLIES TO CONTROL PANEL 230000089 R10 & LATER JUNCTION BOX 230000090 R8 & LATER	JS	CE	01-10-06
REV.		BY	CKD	DATE

Patterson-Kelley
Harsco
 East Stroudsburg, PA 18301
 570-476-7281
 www.pkothers.com

F D LOGIC

REV: FD00000000 1.0



6.1.2 Main Control Panel Components

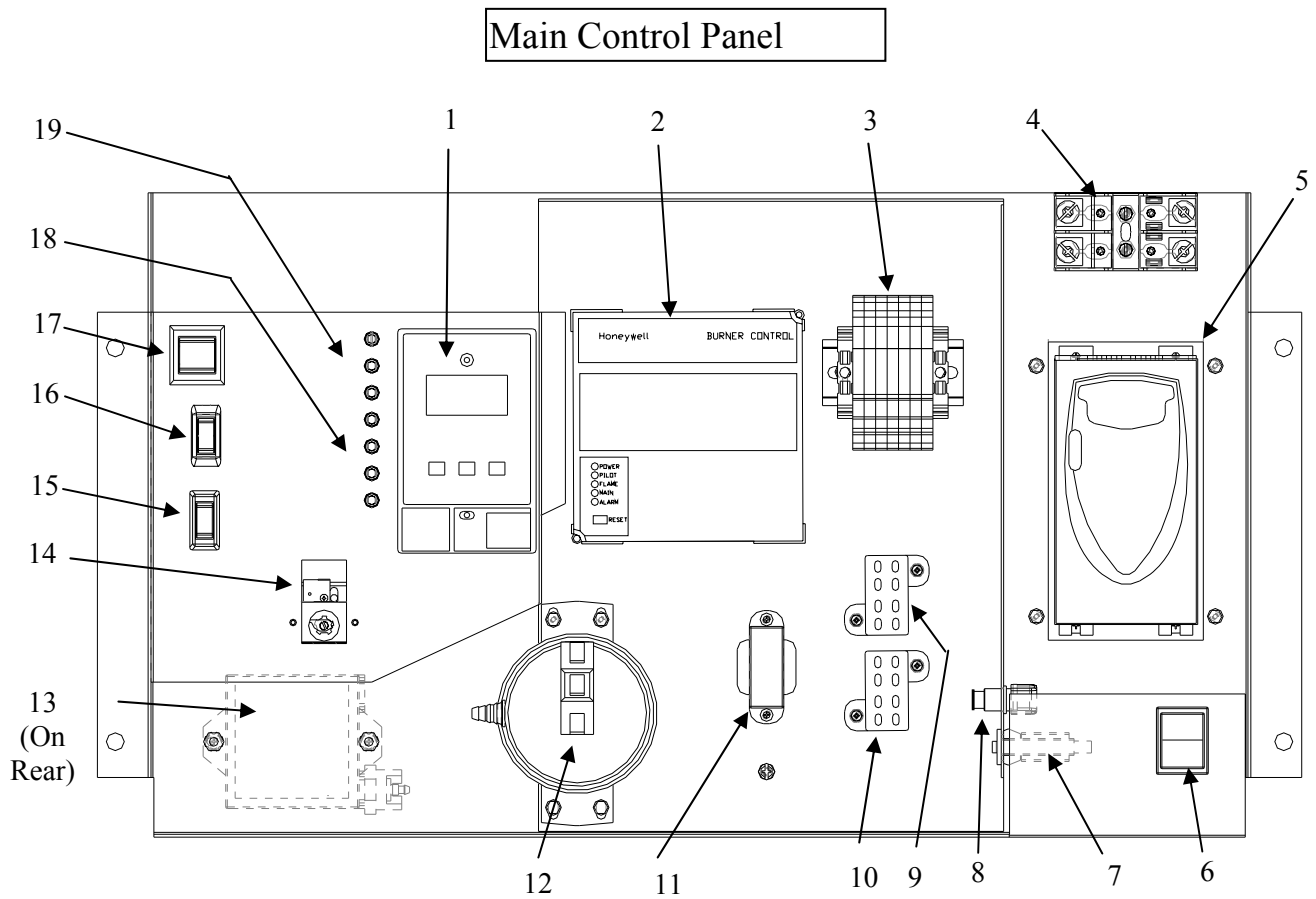

Mark	Description
1	Temperature Control
2	Combustion Control
3	Relays
4	Inverter Fuses
5	Blower/Inverter Control
6	On/Off Switch
7	Circuit Breaker

Mark	Description
8	Inverter Fault Reset
9	Neutral Terminal Block
10	Hot Terminal Block
11	24 V Transformer
12	Airswitch
13	Ignition Transformer
14	High Water Temp Limit

Mark	Description
15	Remote/Local Enable Switch
16	High/Modulate/Low Switch
17	Remote/Local Modulate Switch
18	Green LED Lights (2)
19	Red LED Lights (5)



6.1.3 Main Control Panel Point to Point

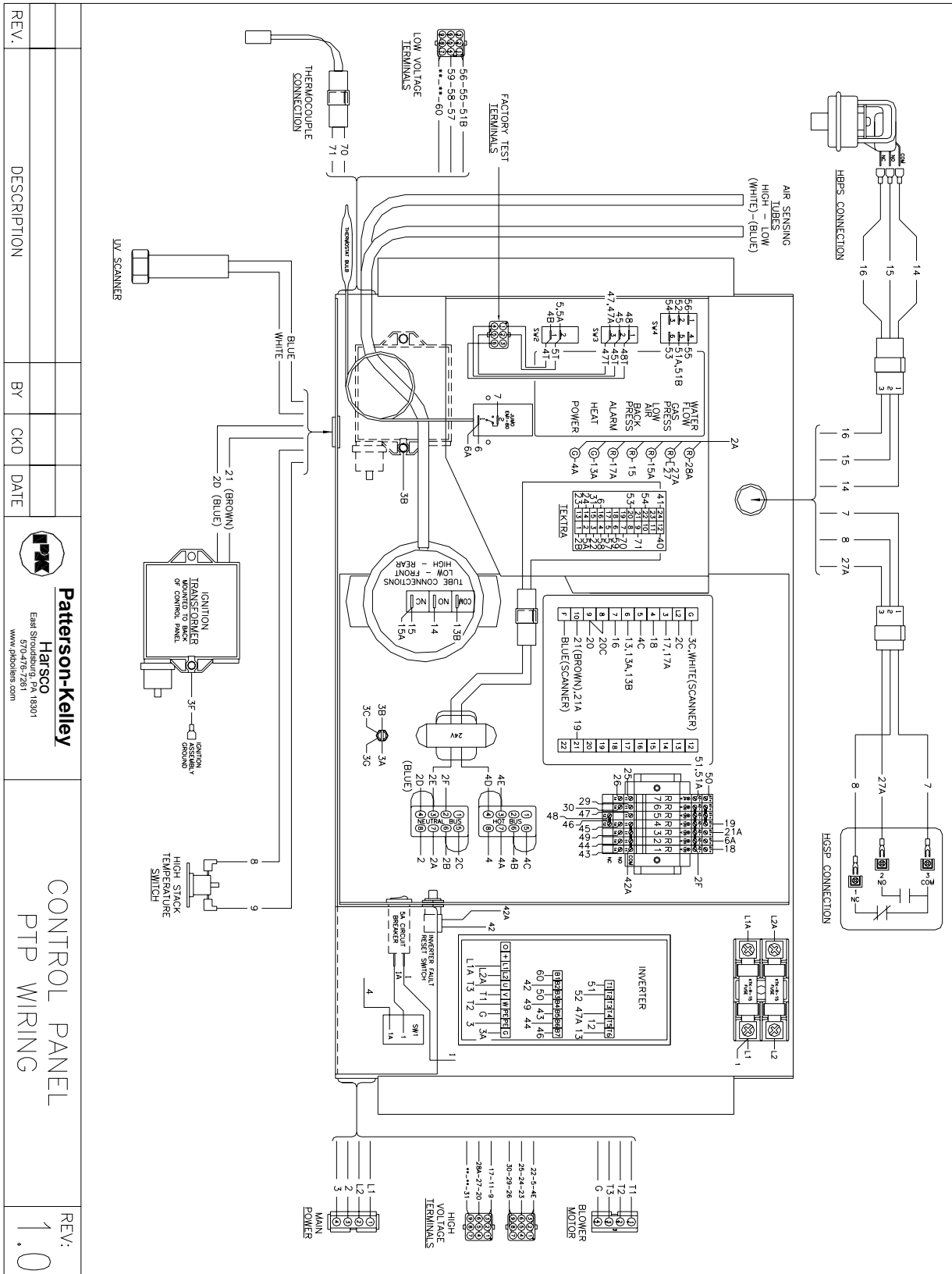

REV.	DESCRIPTION	BY	CKD	DATE

Patterson-Kelley
Harsco
 East Stroudsburg, PA 18041
 570-476-7261
 www.pkoilers.com

CONTROL PANEL
PTP WIRING

REV: **1.0**



6.1.5 Customer Connections Details

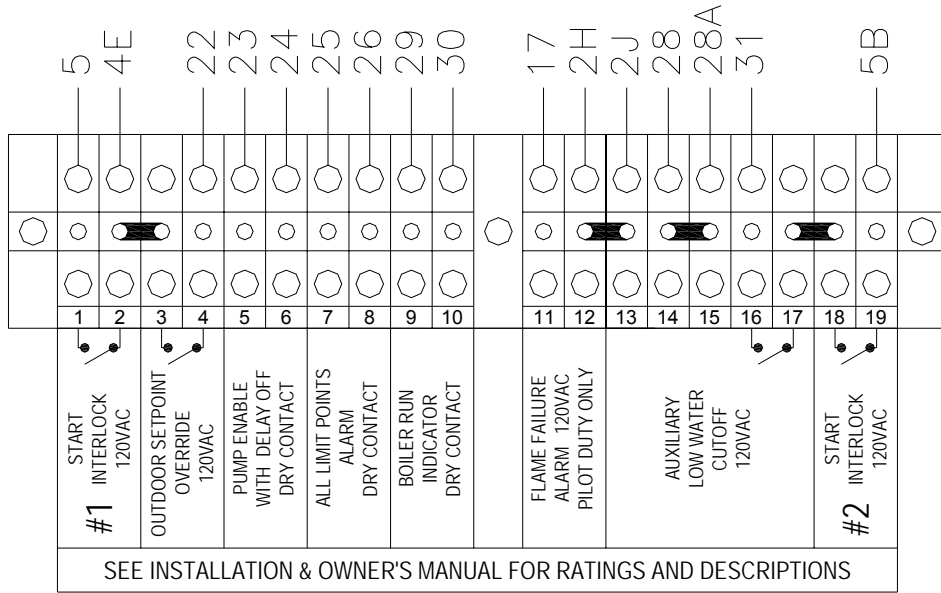

HV STRIP

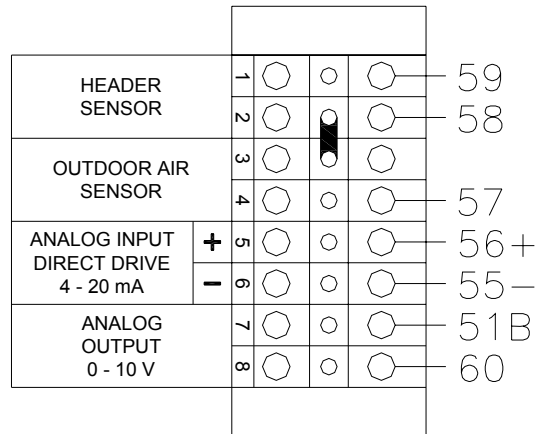

MAIN BLOCK

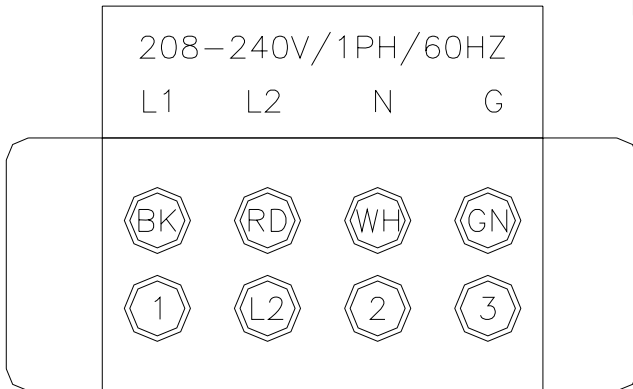

LV STRIP

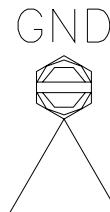



6.1.6 Gas Train

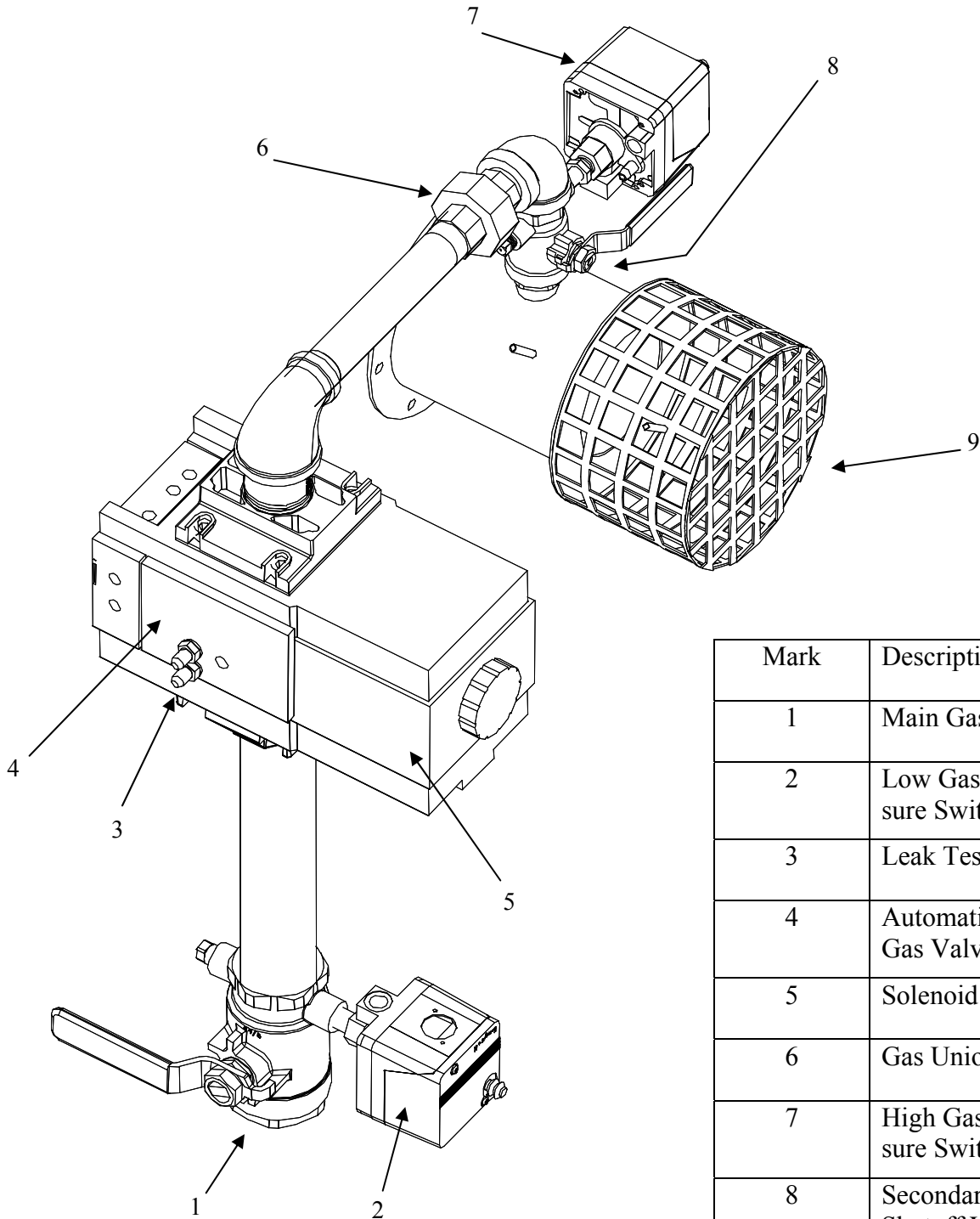

Mark	Description
1	Main Gas Valve
2	Low Gas Pressure Switch
3	Leak Test Ports
4	Automatic Dual Gas Valve
5	Solenoid Coils
6	Gas Union
7	High Gas Pressure Switch
8	Secondary Gas Shutoff Valve
9	Air Gas Mixer Head



6.1.7 Blower/Burner/Ignition Assembly

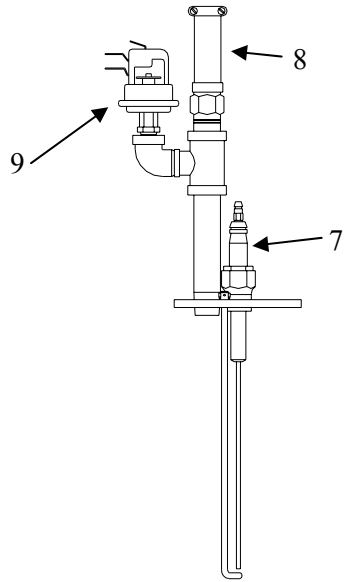
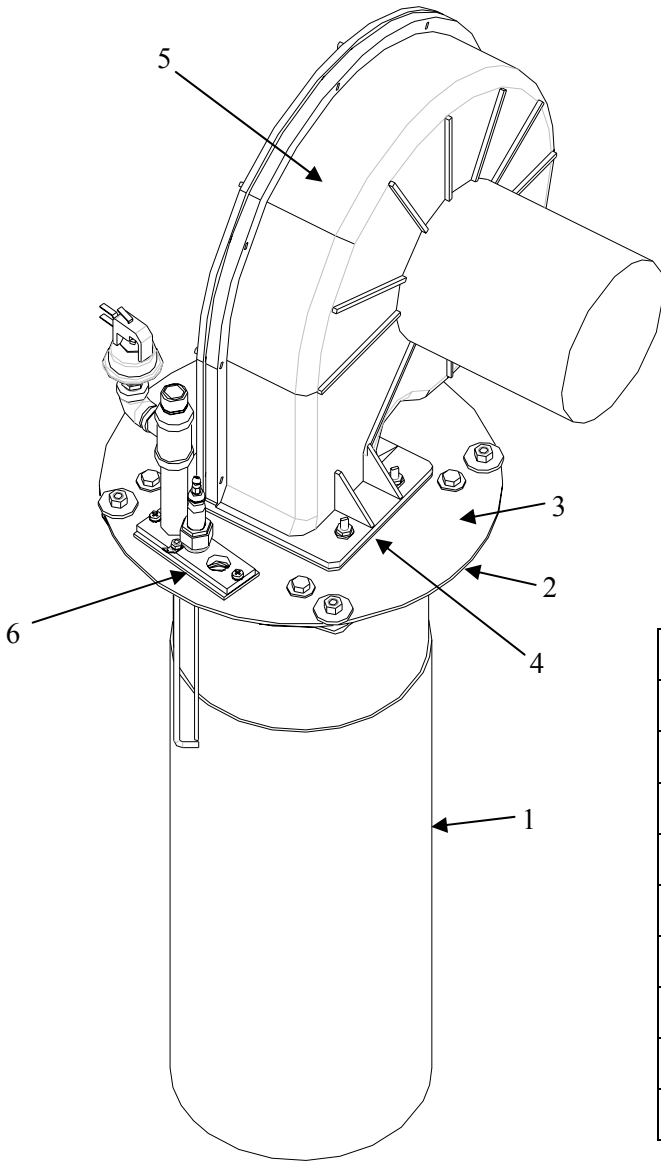

Mark	Description
1	Burner Grid
2	Burner Gasket
3	Mounting Plate
4	Blower Gasket
5	Blower w/Motor
6	Ignition Gasket
7	Ignition Electrode
8	UV Scanner
9	Backpressure Switch



6.1.8 Heat Exchanger and Combustion Chamber

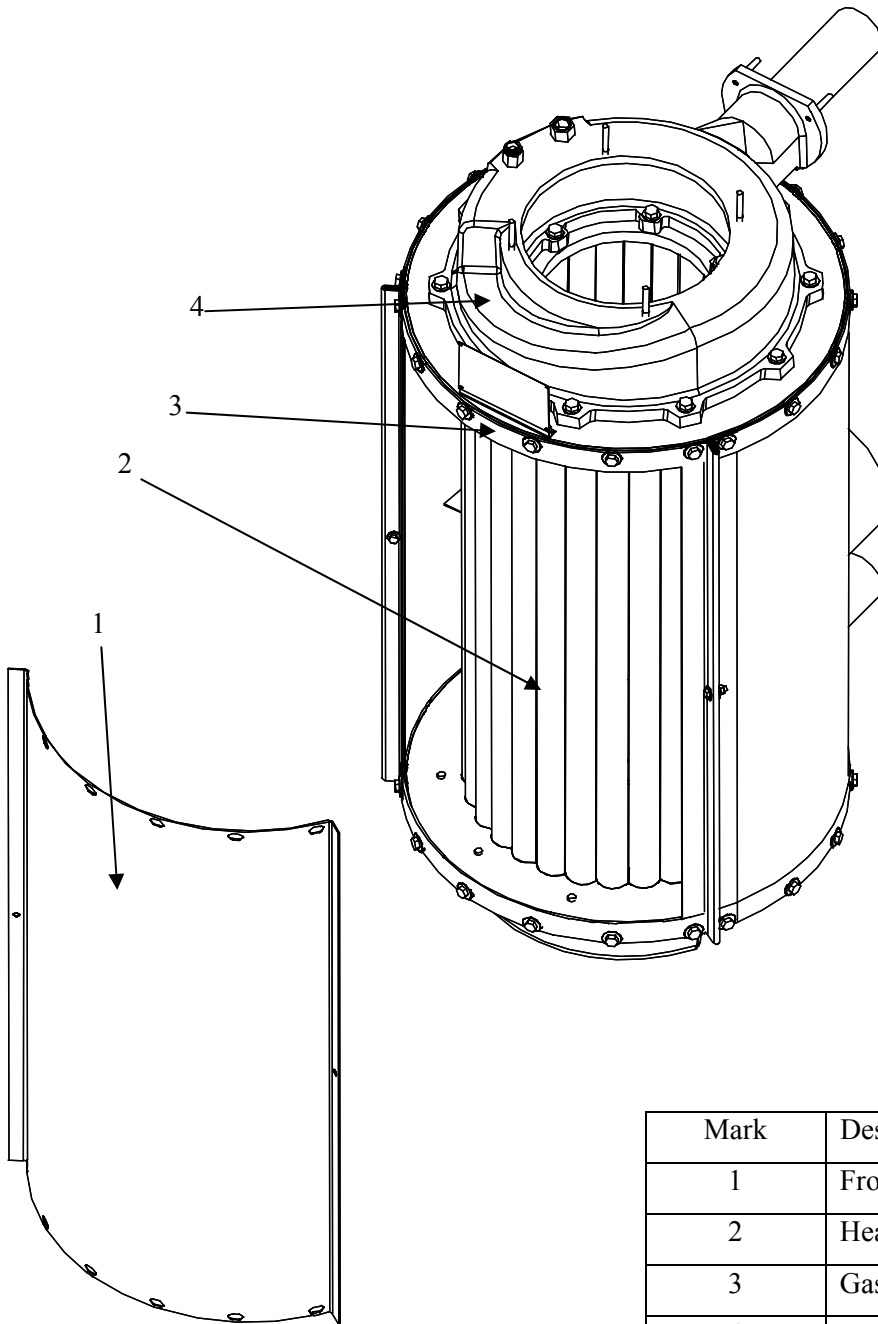

Mark	Description
1	Front Wrapper
2	Heat Exchanger
3	Gasket Set
4	Removable Top Head



6.1.9 Cabinet Assembly

Mark	Description
1	Front Door
2	Side Covers
3	Top Cover
4	Control Panel
5	Relief Valve
6	Flow Switch
7	Low Water Cutoff Switch (optional)
8	Air Inlet Assembly

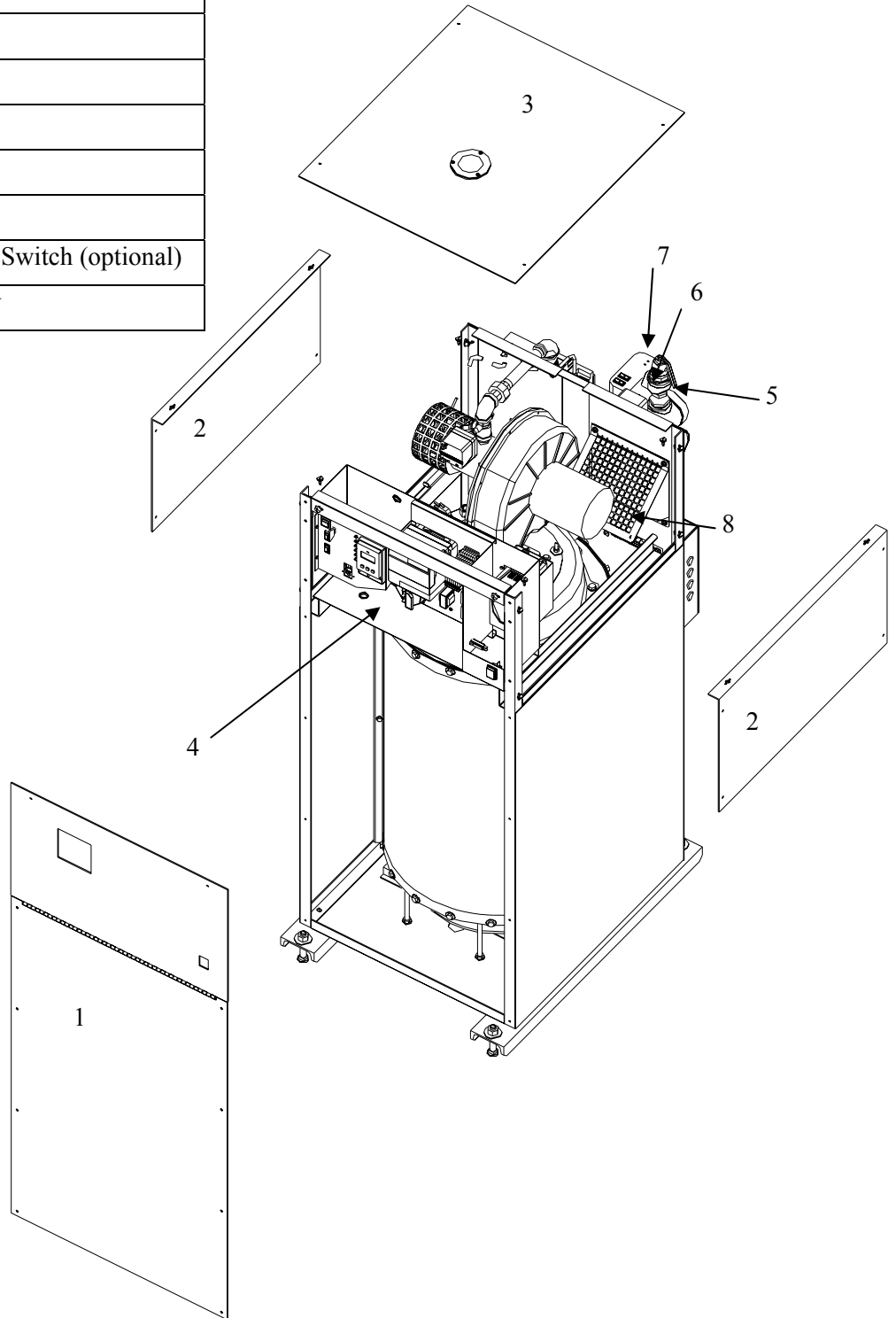



7.0 LIMITED WARRANTY

Subject to the terms and conditions herein and except as provided below with respect to products or parts not manufactured by Patterson - Kelley Co., Seller warrants to the original owner at the original installation site that products manufactured by Seller ("Products") comply, at the time of manufacture, with recognized hydronics industry regulatory agency standards and requirements then in effect and will be free from defects in materials and workmanship for a period of five (5) years from date of shipment (the "Warranty Period"). For products or parts not manufactured by Patterson - Kelley, the warranty obligations shall, in all respects, be limited to one year.

REMEDY

The sole remedy of this warranty is expressly limited to the repair or replacement of any part found to be defective under conditions of normal use within the Warranty Period.

Installation is not included.

Warranty - The owner must notify the original installer of the Product and Seller (Attention: Patterson-Kelley Co., P.O. Box 458, East Stroudsburg, PA 18301), in writing, within the Warranty Period, providing a detailed description of all claimed defects. Transportation to the factory or other designated facility for repairs of any products or items alleged defective shall, in all events, be the responsibility and at the cost of the owner.

EXCLUSIONS

Seller shall have no liability for and this warranty does not cover:

- A. Incidental, special or consequential damages, such as loss of the use of products, facilities or production, inconvenience, loss of time or labor expense involved in repairing or replacing the alleged defective Product.
- B. The performance of any Product under conditions varying materially from those under which such Product is usually tested under industry standards as of the time of shipment.
- C. Any damage to the Product due to abrasion, erosion, corrosion, deterioration, abnormal temperatures or the influence of foreign matter or energy.
- D. The design or operation of owner's plant or equipment or of any facility or system of which any Product may be made a part.
- E. The suitability of any Product for any particular application.
- F. Any failure resulting from misuse, modification not authorized by Seller in writing, improper installation or lack of or improper maintenance.
- G. Equipment furnished by the owner, either mounted or unmounted, or when contracted for by the owner to be installed or handled.
- H. Leakage or other malfunction caused by:

- 1. Defective installations in general and, specifically, any installation which is made:
 - a. in violation of applicable state or local plumbing housing or building codes,
 - b. contrary to the written instructions furnished with this unit
- 2. Adverse local conditions in general and, specifically, sediment or lime precipitation in the tubes and/or headers or corrosive elements in the atmosphere.
- 3. Misuse in general and, specifically, operation and maintenance contrary to the written instructions furnished with the unit, disconnection, alteration or addition of components or apparatus, not approved by seller, operation with fuels or settings other than those set forth on the rating plate or accidental or exterior damage.
 - I. Production of noise, odors, discoloration or rusty water.
 - J. Damage to surrounding area or property caused by leakage or malfunction.
 - K. Costs associated with the replacement and/or repair of the unit including: any freight, shipping or delivery charges, any removal, installation or reinstallation charges, any material and/or permits required for installation, reinstallation or repair, charges to return the boiler and or components. Seller's liability under this warranty shall not in any case exceed the amount paid for the Product found to be defective.

THIRD-PARTY WARRANTIES

For goods or components not manufactured by Seller, the warranty obligations of Seller shall, in all respects, conform and be limited to one year from the date of shipment.

SEVERABILITY

To the extent that any provision of this warranty would be void or prohibited under applicable law, such provisions shall be limited in effect to the minimum extent necessary to render the remaining provisions hereof enforceable.

NO OTHER WARRANTIES

Seller makes no implied warranty of merchantability or fitness for a particular purpose or other warranties with respect to any products or services except as expressly set forth in this limited warranty



8.0 FIELD STARTUP REPORT



Established 1880

Patterson-Kelley

Harsco

MODU-FIRE® FORCED DRAFT BOILER START-UP REPORT

Boiler Serial # _____ Model #: _____ Date: _____

Installation Name: _____ Address: _____ City: _____

State: _____ Zip: _____ Contact: _____ Phone: _____

Installer Name: _____ Type of Installation: _____

1. Factory Fire-Test: (copy from boiler label)		
	High	Low
Inlet Gas	_____ "w.c.	_____ "w.c.
Oxygen (O2)	_____ %	_____ %
Carbon Dioxide (CO2)	_____ %	_____ %
Carbon Monoxide (CO)	_____ ppm	_____ ppm
Stack Temperature (net)	_____ ° F	_____ ° F
Main Flame Signal	_____ Volts	_____ Volts
Inlet Air Temperature	_____ ° F	_____ ° F

2. Sealed Combustion YES / NO

2a. Combustion Air Temperature _____ ° F

2b. Approximate Elevation (ft) _____

3. Water Inlet temperature: _____ ° F

4. Water Outlet temperature: _____ ° F

5. Water Flow (gpm) _____

5a. Glycol ? YES / NO

6. Operating Temperature Setpoint: _____ ° F
(from internal OR external control)

7. Gas Valve a.Low Fire Setting (N) _____
b.High Fire Setting (V) _____

Start-Up Field Test: DATE: _____		
	High	Low
Inlet Gas	_____ "w.c.	_____ "w.c.
Oxygen (O2)	_____ %	_____ %
Carbon Dioxide (CO2)	_____ %	_____ %
Carbon Monoxide (CO)	_____ ppm	_____ ppm
Stack Temperature (net)	_____ ° F	_____ ° F
Main Flame Signal	_____ Volts	_____ Volts
Inlet Air Temperature	_____ ° F	_____ ° F

8. Approximate stack lengths:
_____ Ft. Horizontal
_____ Ft. Vertical
_____ Flue Pipe Diameter

9. Electrical Supply Power L1 to L2 _____ Volts
L1 to N _____ Volts
Less than 1 volt between neutral and ground YES / NO

10. Total cycles: _____

11. Total hours _____

12. Any Faults? Describe with code, time, and description _____

Performed by: _____

Additional Comments: _____





Notes: