

Rep Name: _____

Email: _____

Phone Number: _____

Date: / / /

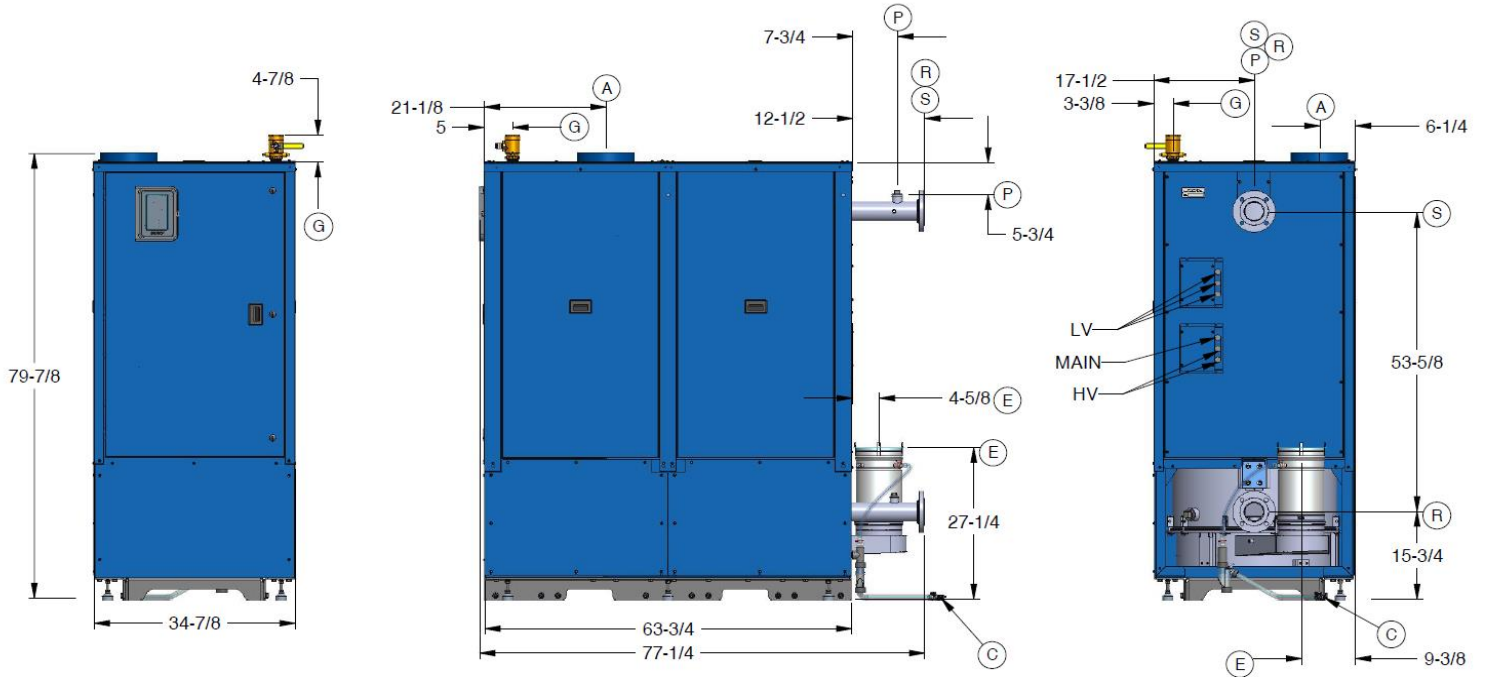

Primary dimensions are in inches. The secondary dimensions, [in brackets], are in millimeters.

This boiler requires Category IV venting (condensing-positive pressure) or Category II venting† (condensing -negative pressure as defined in ANSI Z223.1/NFPA 54/CSA-B.149 latest edition.

†Category II venting must include the optional combustion air damper

BOILER CONECTIONS		
A	Combustion Air Inlet	10" dia. stub
C	Condensate Drain	3/4" hose
E	Exhaust Vent	8" (1500 & 2000) 10" (2500 & 3000)
G	Natural Gas	1-1/2" NPT-F (1500 & 2000) 2" NPT-F (2500 & 3000)
J	Wiring Junction Boxes	inside cabinet
P	Pressure Relief Valve	see list for options
R†	Boiler Return	3" pipe, flanged
S†	Boiler Supply	3" pipe, flanged

P-K SOLIS™

Boiler Models SL-1500, SL-2000, SL-2500, & SL-3000
Natural Gas with NURO® Control



PATTERSON-KELLEY

BOILER CONTROLS
ASME CSD-1 is standard
Complies with: GE GAP (IRI) guidelines GAP.4.1.0 and GAP.4.1.3 FM Global 6-4 Section 1.0
Main Gas Train with Dual Shut-off
Integrated Boiler Control, NURO Series
Operating Thermostat, 42 ^o -195 ^o F (5.6 ^o -91 ^o C)
High Limit Thermostat, Manual Reset, 100 ^o -197 ^o F (38 ^o -92 ^o C)
High Exhaust Back Pressure Switch
LWCO/Flow Switch, Paddle Type & LWCO, Probe Type
Combustion Air Proving Switch, Differential Pressure Type
Combustion Blower, Variable Speed, 1625 Watt

A.S.M.E. SECTION IV DESIGN DATA	SL-1500	SL-2000	SL-2500	SL-3000
Max Pressure	160 PSIG			
Max Allowable Temperature	210°F			
Max Setpoint	185°F			
Flow Rate @ 20°FΔT	144 GPM	192 GPM	240 GPM	288 GPM
Min Flow Rate @ All Firing Rates	20 GPM	20 GPM	25 GPM	25 GPM

MODEL SELECTION				
Boilers	<input type="checkbox"/> SL-1500	<input type="checkbox"/> SL-2000	<input type="checkbox"/> SL-2500	<input type="checkbox"/> SL-3000
Fuel Options	<input type="checkbox"/> NG			
Min Inlet Gas Pressure	3.5" w.c.			
Max Inlet Gas Pressure	14" w.c.			
Max Input (BTU/hr)	1,500,000	2,000,000	2,500,000	3,000,000
Max Output (BTU/hr)	1,440,000	1,920,000	2,400,000	2,880,000
Boiler HP	44.8	59.7	74.7	89.6
Min Input (BTU/hr)	150,000	200,000	250,000	300,000
Min Output (BTU/hr)	144,000	192,000	240,000	288,000
Turndown Ratio	10:1			
Operating Weight	3000 lbs.	3000 lbs.	3470 lbs.	3470 lbs.
Shipping Weight	2445 lbs.	2445 lbs.	2650 lbs.	2650 lbs.
Boiler Water Content	117 gal	117gal	149 gal	149 gal
Shipping Dimensions	77.3"x35"x80" (LxWxH)		80"x35"x80" (LxWxH)	
Power Supply	208/240V, 1ph, 60Hz		220/480V, 3ph, 60Hz	
Operating Current	15 Amps	10 Amps	20 Amps	20 Amps
Recommended Minimum Circuit Capacity	20 Amps	15 Amps	25 Amps	25 Amps

PRESSURE RELIEF VALVE/PRESSURE-TEMPERATURE GAUGE		
Shipped Loose for Field Installation		
<input type="checkbox"/>	30 PSIG 1-1/2"x 2"	15-160 psi/0-250°F
<input type="checkbox"/>	60 PSIG 1-1/4"x 1-1/4"	15-160 psi/0-250°F
<input type="checkbox"/>	75 PSIG 1-1/4"x 1-1/4"	15-160 psi/0-250°F
<input type="checkbox"/>	80 PSIG 1-1/4"x 1-1/4"	15-160 psi/0-250°F
<input type="checkbox"/>	100 PSIG 1"x 1-1/4"	15-160 psi/0-250°F
<input type="checkbox"/>	125 PSIG 1"x 1"	15-160 psi/0-250°F
<input type="checkbox"/>	150 PSIG 1"x 1"	15-160 psi/0-250°F

RECOMMENDED CLEARANCE FOR SERVICE ACCESS				
Front - 30"	Rear - 18"	Top - 24"	Left Side - 12"	Right Side - 0"

Notes:

-Patterson-Kelley reserves the right to make changes at any time without notification