

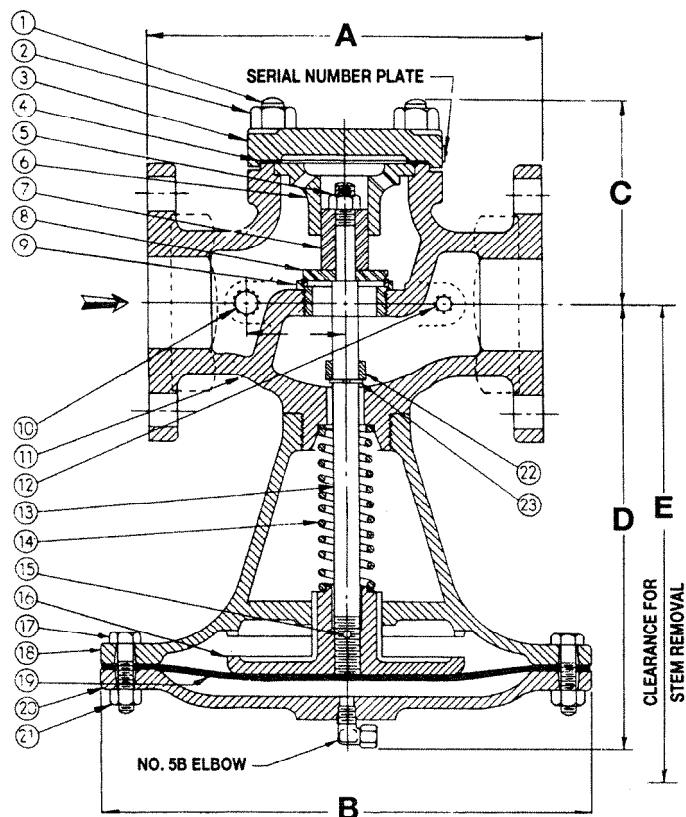

SPENCE ENGINEERING CO., INC., 150 Coldenham Rd., Walden, NY, USA 12586-2035
 Phone: (914) 778-5566 Fax: (914) 778-1072

SD 3002/9405



TYPE E2 MAIN VALVE

TYPE E2 Main Valve

Sizes 3/4" through 12"

The Spence Type E2 Main Valve is of normally closed, single seat design featuring packless construction, Hycar diaphragm and protected main spring.

When controlled by one or more of the various types of Spence Pilots, this valve will accomplish most functions required of a regulator.

CAST IRON RATINGS (Maximum Inlet Conditions)

Valve Ends _____ Pressure _____ (Temperature)

- ANSI NPT Screwed15 PSIG(250°F)
- ANSI 125 Flanged15 PSIG(250°F)

CAST BRONZE RATINGS (Maximum Inlet Conditions)

Valve Ends _____ Pressure _____ (Temperature)

- ANSI NPT Screwed15 PSIG(250°F)

DIMENSIONS (inches), **WEIGHTS** (pounds)
AND RATED FLOW COEFFICIENTS (Cv)

SIZE	A		OTHER DIMENSIONS				APPROX. WT.		Cv
	CI, BRZ	CI	B	C	D	E	CI, BRZ	CI	
	ANSI NPT	ANSI 125					ANSI NPT	ANSI 125	
3/4	4 3/4	—	8	2 7/8	7 3/4	11 1/2	18	—	7.6
1	5 3/8	5 1/2	8	3 5/8	8 1/8	12 1/2	19	21	11.7
1 1/4	6 1/2	6 3/4	9	4 1/8	8 1/4	12 1/2	30	33	18.9
1 1/2	7 1/4	6 7/8	9 3/4	4 3/8	8 3/4	13 1/4	36	40	27.4
2	7 1/2	8 1/2	10 1/2	5 1/4	10	15 1/4	50	57	44
2 1/2	—	9 3/8	10 1/2	5 3/4	11 1/2	17 3/4	—	70	68
3	—	10	11 1/4	6 5/8	12 3/4	19 3/4	—	98	96
4	—	11 7/8	13 1/2	6 3/4	13 5/8	21 1/4	—	135	143
5	—	13 5/8	14 1/4	7 1/2	15	23	—	185	202
6	—	15 1/8	16	7 7/8	16 5/8	26	—	250	255
8	—	19	20	9 1/2	19 7/8	30 1/2	—	415	465
10	—	23 5/8	24	10 7/8	23 7/8	38 1/2	—	690	748
12	—	26 1/2	28	12 3/4	27 1/8	44 1/4	—	1060	1118

PRINTED IN U.S.A.

OPERATING PRINCIPLE

The regulator is operated by initial steam or fluid pressure. It is normally closed, being held so by initial pressure on the disc and by an internal main spring. When the pilot is opened (see pilot instructions), initial pressure flows through the pilot to the 8B tee. Bleedport 4A restricts the flow and pressure builds under the diaphragm and opens the main valve.

Delivery pressure feeds back through the control pipe to the pilot diaphragm. As this pressure approaches a balance with the thrust of the adjusting spring, the pilot throttles the loading pressure. In turn, the main valve takes a position established by the loading pressure where just enough steam flows to maintain the set delivery pressure.

RECOMMENDED INSTALLATION

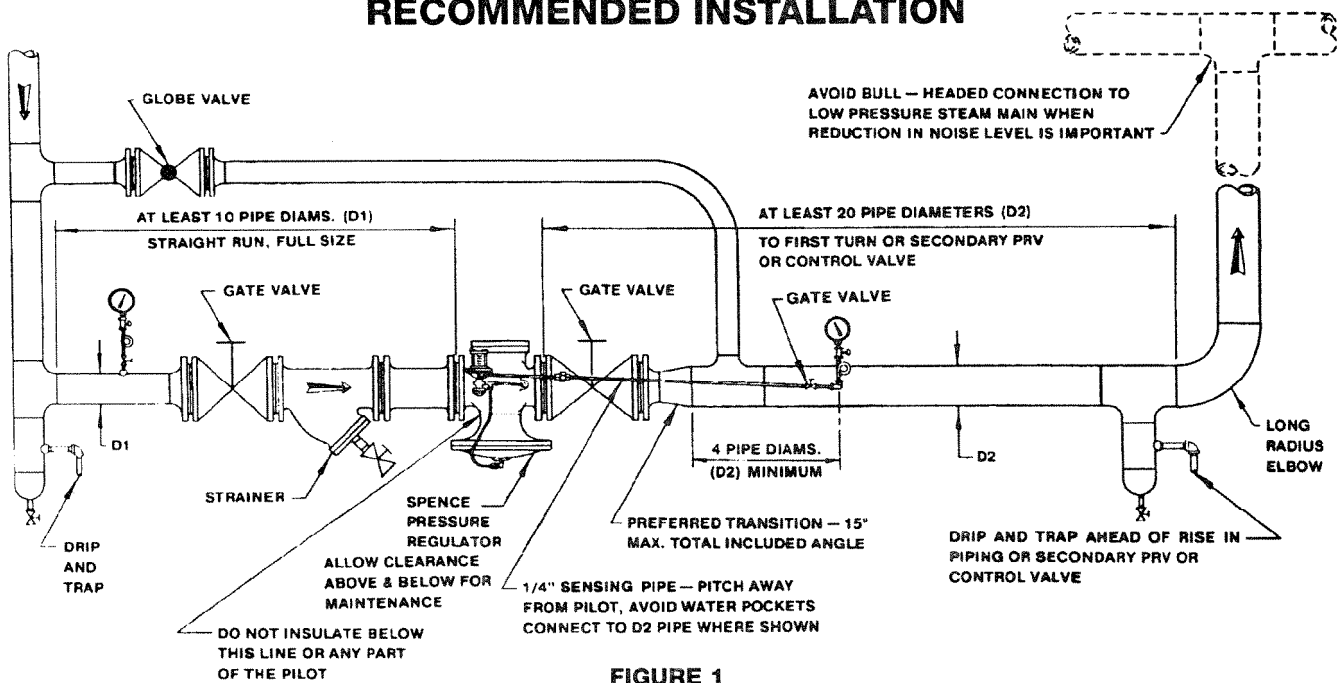

FIGURE 1

INSTALLATION

PLANNING

Locate the valve in a straight run of horizontal pipe. Allow headroom above the valve for access through the blind flange. Provide clearance for stem withdrawal underneath. Prevent water hammer and erratic operation by installing traps to provide proper drainage before and after the valve and before secondary PRV or control valve. Avoid damaging effects of scale and dirt in pipe lines by using a strainer as shown in Figure 1. Provide a 3-valve by-pass to facilitate inspection without interrupting service.

To eliminate excessive noise and erratic regulation with steam and other compressible fluids, enlarge the delivery pipe size to effect a reasonable flow velocity at the reduced pressure. A tapered transition is recommended. If possible, avoid a sharp turn close to the regulator outlet and a bull-headed tee connection to the low pressure main.

Install initial and delivery pressure gages to indicate performance. If the pressure rating of the delivery system or connected equipment is less than the initial steam pressure, provide a safety valve.

MAIN VALVE

Flush the piping system thoroughly to clear it of welding beads, scale, sand, etc. Mount the main valve with diaphragm chamber down and arrow on body pointing in the direction of flow. Screwed end valves should be mounted in unions.

PILOT

Mount the pilot on either side of the main valve by means of 1/4" nipple and union provided. Make this connection the the 1/4" pipe tap at the inlet of the main valve as shown in Figure 2.

Screw No. 4A bleedport fitting into the 1/8" pipe tap at the outlet of the main valve body. Note bleed orifice in this fitting - vital to operation of regulator.

Screw No. 8B tee into 1/8" pipe tap in pilot. Select tap facing downstream.

Screw No. 5B elbow into 1/8" pipe tap on underside of main valve diaphragm chamber.

Connect tubing bends as illustrated in Fig. 2.

CONTROL PIPE (if required)

Use 1/4" pipe for this line which connects the pilot diaphragm chamber to the desired point of pressure control. Take the control at a point of minimum turbulence. Avoid control immediately at the valve outlet or after a turn. When the delivery pipe expands in size, select a spot at least 4 pipe diameters beyond the point of enlargement. Pitch away from pilot to avoid erratic operation and excessive fouling. Eliminate water pockets. Locate delivery pressure gage in control pipe to show pressure actually reaching pilot diaphragm.

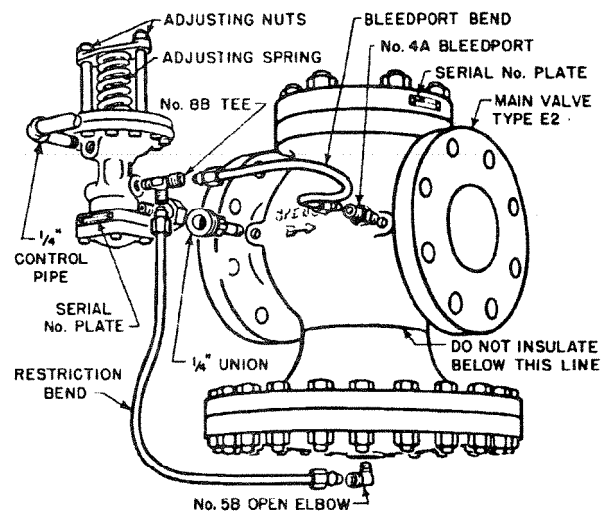

FIGURE 2

MAINTENANCE

INSPECTION

Under normal conditions, complete dismantling at regular intervals is not recommended. A valve kept relatively free of dirt will function for years with minimum attention.

After the first few days of operation and twice a year, the following should be checked.

1. Inspect for dirt collected at bleedport No. 4A.
2. Inspect all joints for leakage. Keep bolts tight. Never allow a leak to persist.

DISMANTLING MAIN VALVE

Connect a source of air or water pressure which can be adjusted by hand to the No. 5B elbow. Apply pressure to jack valve open and prevent stem from turning while removing stem nuts. Usually 30 psi will suffice. Use penetrating oil on the threads.

REPLACING SEAT RINGS

These joints should be made up with Copaltite, Permatex or equal high temperature gasket compound. Remove old compound from body and seat ring with a wire brush. Apply new compound sparingly to both parts, threads and shoulders. Let stand until tacky before assembling.

GRINDING IN

Seats and discs should never require more than the lightest touch up with very fine (400 grit) grinding compound. Heavy grinding will produce galling, wider seating surface and a groove in the disc, all of which tend to cause leakage. Reface a damaged surface before attempting to grind it in. Grind sparingly.

Main stem (13) is slotted for rotation with a screwdriver. Valve spring (14) is omitted from the assembly during grinding. Slip the stem into its normal position. Apply compound to the disc, place it on the stem and guide plug, tighten with stem nut.

After grinding, disassemble and clean all parts.

VALVE SIZE	TYPE E2	
	HOOD (K)	TOTAL
3/4	1/4	1/8
1	5/16	3/16
1-1/4	3/8	7/32
1-1/2	7/16	1/4
2	9/16	9/32
2-1/2	11/16	11/32
3	13/16	13/32
4	15/16	15/32
5	1-1/16	17/32
6	1-3/16	19/32
8	1-9/16	25/32
10	1-15/16	31/32
12	2-5/16	1-5/32

VALVE SETTING

Valve setting is gaged at K to establish correct stem length and diaphragm position. Dimension K is supplied with each replacement stem.

To install new stem (13), fasten disc (8) and guide plug firmly on stem with stem nut. Insert stem and disc assembly in valve and screw on pressure plate (16). Omit spring (14) for this operation. Hold disc on seat and adjust position of pressure plate until valve setting K is reached. Push pressure plate against stops in base (18). Remove disc, drop out pressure plate and stem, drill and insert dowel pin (15) to lock the joint. Grind off stem projection flush with face of pressure plate.

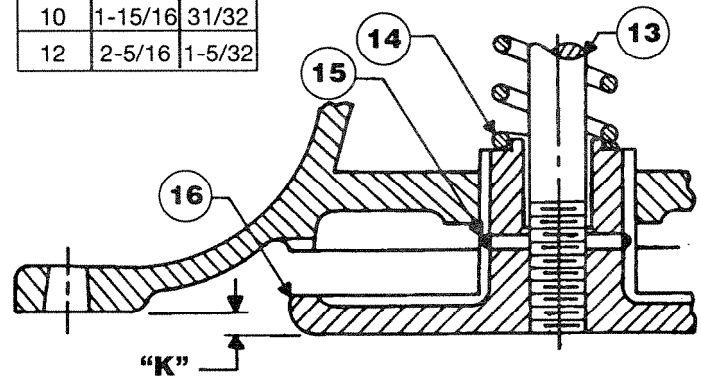

FIGURE 3

START-UP AND SETTING

On pressure reducing valves like the E2D, use by-pass to fill the delivery system and raise pressure to slightly below normal required. Close pilot by releasing compression on adjusting spring. See Figure 2. Open 1/4" control pipe valve. Crack outlet stop valve. Crack inlet stop valve. Blow down strainer. **Caution: Never open a reducing valve without positive indication that the high side is clear of condensate.**

Open inlet stop valve and gradually compress adjusting spring until the valve opens and takes control at desired pressure. Alternately choke down on the by-pass and open outlet stop valve until the regulator is on the line. See individual instructions for other pilots.

TROUBLE SHOOTING

FAILURE TO OPEN OR SAGGING DELIVERY PRESSURE

1. Adjusting spring on pilot may have been tampered with.
2. Initial pressure may be down due to partially closed supply valve, clogged strainer or other obstruction.
3. No. 4A bleedport fitting may have been omitted and an open coupling substituted.
4. Control pipe may be plugged. Most likely points of obstruction are at shutoff valve and entrance to delivery main.
5. Main diaphragm may be broken. Test with air or water before dismantling.

FAILURE TO CLOSE OR OVER-RIDING DELIVERY PRESSURE

1. Adjusting spring on pilot may have been tampered with.
2. Orifice in bleedport No. 4A may be plugged.

3. By-pass valve may be leaking.
4. On pressure regulators like the ED2, the main valve or pilot may be held open by foreign matter in seat. To determine which valve leaks, first close inlet stop valve and 1/4" control pipe valve. Then remove bleedport bend so pilot will exhaust to atmosphere. Crack inlet stop valve. Steam will issue from No. 8B tee. Release compression on adjusting spring to see if pilot closes tight. Open and close several times to wash seat. Steam blowing back from bleedport means main valve disc is held open by foreign matter. Steam may wash the obstruction from the seat if the valve is made to open wide. This can be accomplished, even at light loads, if the control point is beyond the outlet stop valve. Reassemble bleedport bend and place regulator in operation. Then, slowly open and close outlet stop valve.

CAST IRON & BRONZE PARTS LIST – 3/4" to 3"

ITEM NO.	PART NAME	MATERIAL	VALVE SIZE						
			3/4	1	1 1/4	1 1/2	2	2 1/2	3
1	Blind Flange Stud	Steel	04-05516-00	04-10118-00	04-05442-00	04-05443-00	04-10119-00	04-10119-00	04-05443-00
2	Blind Flange Nut	Steel	05-02847-00	05-02851-00	05-02854-00	05-02856-00	05-02860-00	04-02860-00	05-02856-00
3	Blind Flange	Cast Iron	04-02171-00	04-02173-00	04-02176-00	04-02178-00	04-02180-00	04-02185-00	04-02157-00
	Blind Flange	Bronze	04-02172-00	04-02174-00	04-02177-00	04-02179-00	04-02181-00	—	—
4	*Gasket	Non-Asbestos	05-02381-00	05-02362-00	05-02382-00	05-02365-00	05-02366-00	05-02367-00	05-02369-00
5	*Stem Nut	Steel	05-02969-00	05-02970-00	05-02970-00	05-02971-00	05-02971-00	05-02972-00	05-02973-00
6	Disc Guide Plate	Cast Iron	04-03576-00	04-03479-00	04-03480-00	04-03478-00	04-03500-00	04-03509-00	04-03496-00
7	Guide Plug	Stainless Steel	—	—	—	04-03751-01	04-03750-00	04-03754-00	04-03755-00
8	*Integral Disc	Stainless Steel	04-01813-02	04-01832-02	04-01850-02	04-01870-02	04-01888-02	04-01906-01	04-01918-00
9	*Seat Ring	Stainless Steel	04-04075-01	04-04084-01	04-04092-01	04-04496-01	04-11593-00	04-11549-00	04-11549-00
10	Pipe Plug 1/4"	Steel	04-03772-00	04-03772-00	04-03772-00	04-03772-00	04-03772-00	04-03772-00	04-03772-00
	Pipe Plug 1/4"	Brass	04-03771-00	04-03771-00	04-03771-00	04-03771-00	04-03771-00	—	—
11	NPT Body	Cast Iron	04-00868-00	04-00869-01	04-00871-01	04-00873-01	04-00875-01	—	—
	NPT Body	Bronze	04-08279-00	04-06932-00	04-09762-00	04-08749-00	04-01568-00	—	—
	125 Body	Cast Iron	—	04-08176-00	04-09964-00	04-09965-00	04-00877-00	04-00879-00	04-00881-00
12	Pipe Plug 1/8"	Steel	04-03769-00	04-03769-00	04-03769-00	04-03769-00	04-03769-00	04-03769-00	04-03769-00
	Pipe Plug 1/8"	Brass	04-03770-00	04-03770-00	04-03770-00	04-03770-00	04-03770-00	—	—
13	*Stem	Stainless Steel	08-08765-00	08-08766-00	08-08766-00	08-08767-00	08-08768-00	08-08769-00	08-08770-00
14	*Main Spring	Steel	05-05093-01	05-05093-01	05-05094-01	05-05095-01	05-05096-01	05-05097-01	05-05098-01
15	*Groove Pin	Steel	05-03247-00	05-03247-00	05-03247-00	05-03251-00	05-03251-00	05-03253-00	05-03255-00
16	*Pressure Plate	Cast Iron	04-03621-00	04-03700-00	04-03622-00	04-03623-01	04-03624-00	04-03625-00	04-03626-00
17	Diaphragm Bolt	Steel	05-04770-00	05-04770-00	05-04773-00	05-04773-00	05-04773-00	04-04773-00	05-04774-00
18	Base	Cast Iron	04-00501-00	04-00501-00	04-00509-00	04-00502-00	04-00505-00	04-00506-00	04-00604-00
19	*Diaphragm	Hycar	05-01668-00	05-01668-00	05-01669-00	05-01670-00	05-01671-00	05-01672-00	05-01673-00
20	Hood	Cast Iron	04-02571-00	04-02571-00	04-02605-00	04-02606-00	04-02607-00	04-02608-00	04-02648-00
21	Diaphragm Nut	Steel	05-02872-00	05-02872-00	05-02874-00	05-02874-00	05-02874-00	05-02874-00	05-02874-00
22	Stem Washer	Stainless Steel	04-06130-00	04-06131-00	04-10048-00	04-06132-00	04-06247-00	04-06248-00	04-06249-00
23	Retaining Ring	Stainless Steel	05-09382-00	05-09383-00	05-09383-00	05-09384-00	05-09392-00	05-09385-00	05-09386-00
24	Top Flange	Cast Iron	04-02246-00	04-02248-00	04-02250-00	04-02252-00	04-02233-00	04-02259-00	04-02261-00
	Repair Kit		08-07940-00	08-07941-00	08-07942-00	08-07943-00	08-07944-01	08-07945-01	08-07946-01

CAST IRON & BRONZE PARTS LIST – 4" to 12"

ITEM NO.	PART NAME	MATERIAL	VALVE SIZE					
			4	5	6	8	10	12
1	Blind Flange Stud	Steel	04-05443-00	04-10119-00	04-10120-00	04-10120-00	04-10120-00	04-05455-00
2	Blind Flange Nut	Steel	05-02856-00	05-02860-00	05-02860-00	05-02860-00	05-02860-00	05-02864-00
3	Blind Flange	Cast Iron	04-02157-00	04-02158-00	04-02162-00	04-02165-00	04-02167-00	04-02169-00
4	*Gasket	Non-Asbestos	05-02369-00	05-02371-00	05-02397-00	05-02374-00	05-02375-00	04-02398-00
5	*Stem Nut	Steel	05-02973-00	05-02947-00	05-02975-00	05-03044-00	05-03045-00	05-02977-00
6	Disk Guide Plate	Cast Iron	04-03496-00	04-03504-00	04-03473-00	05-03474-00	05-03497-00	05-03475-00
7	Guide Plug	Stainless Steel	04-03756-00	04-03757-00	04-03742-00	04-03743-00	04-03744-00	04-03745-00
8	*Integral Disc	Stainless Steel	04-01922-00	04-01931-00	04-01940-00	04-01995-00	04-01951-00	04-01700-00
9	*Seat Ring	Stainless Steel	04-11759-00	04-11666-00	04-15802-00	07-43794-00	07-43795-00	07-40509-00
10	Pipe Plug 1/4"	Steel	04-03772-00	04-03772-00	04-03772-00	04-03772-00	04-03772-00	04-03772-00
11	125 Body	Cast Iron	04-00883-00	04-00884-01	04-00885-01	04-00887-01	04-00888-01	04-00726-00
12	Pipe Plug 1/8"	Steel	04-03769-00	04-03769-00	04-03769-00	04-03769-00	04-03769-00	04-03769-00
13	*Stem	Stainless Steel	08-08771-00	08-08772-00	08-08773-00	08-08774-00	08-08775-00	08-08776-00
14	*Main Spring	Steel	05-05099-01	05-05100-01	05-05101-01	05-05102-01	05-05103-01	05-05104-01
15	*Groove Pin	Steel	05-03256-00	05-03257-00	05-03259-00	05-03260-00	05-03262-00	05-03262-00
16	*Pressure Plate	Cast Iron	04-03627-00	04-03628-01	04-03629-00	04-03630-00	04-03631-00	04-03632-00
17	Diaphragm Bolt	Steel	05-04774-00	05-04775-00	05-04780-00	05-04780-00	05-04782-00	05-04787-00
18	Base	Cast Iron	04-00507-00	04-00510-01	04-00511-00	04-00514-00	04-00512-01	04-00513-01
19	*Diaphragm	Hycar	05-01674-00	05-01675-00	05-01676-00	05-01677-00	04-01678-00	04-01679-00
20	Hood	Cast Iron	04-02609-00	04-02618-00	04-02610-00	04-02611-00	04-02612-00	04-02614-00
21	Diaphragm Nut	Steel	05-02874-00	05-02874-00	05-02877-00	05-02877-00	05-02877-00	05-02881-00
22	Stem Washer	Stainless Steel	04-06249-00	04-06270-00	04-06250-00	04-06251-00	04-06271-00	04-06272-00
23	Retaining Ring	Stainless Steel	05-09386-00	05-09387-00	05-09388-00	05-09389-00	05-09390-00	05-09391-00
24	Top Flange	Cast Iron	04-02261-00	04-02263-00	04-02268-00	04-02266-00	—	—
	Repair Kit		08-09587-01	08-10980-00	08-10995-00	—	—	—

*These parts furnished in Repair Kit

**When ordering parts, it is essential that the valve type, size, service and serial number be stated.
Select part by item number, but order by part number.
Specify complete part number when ordering.**