

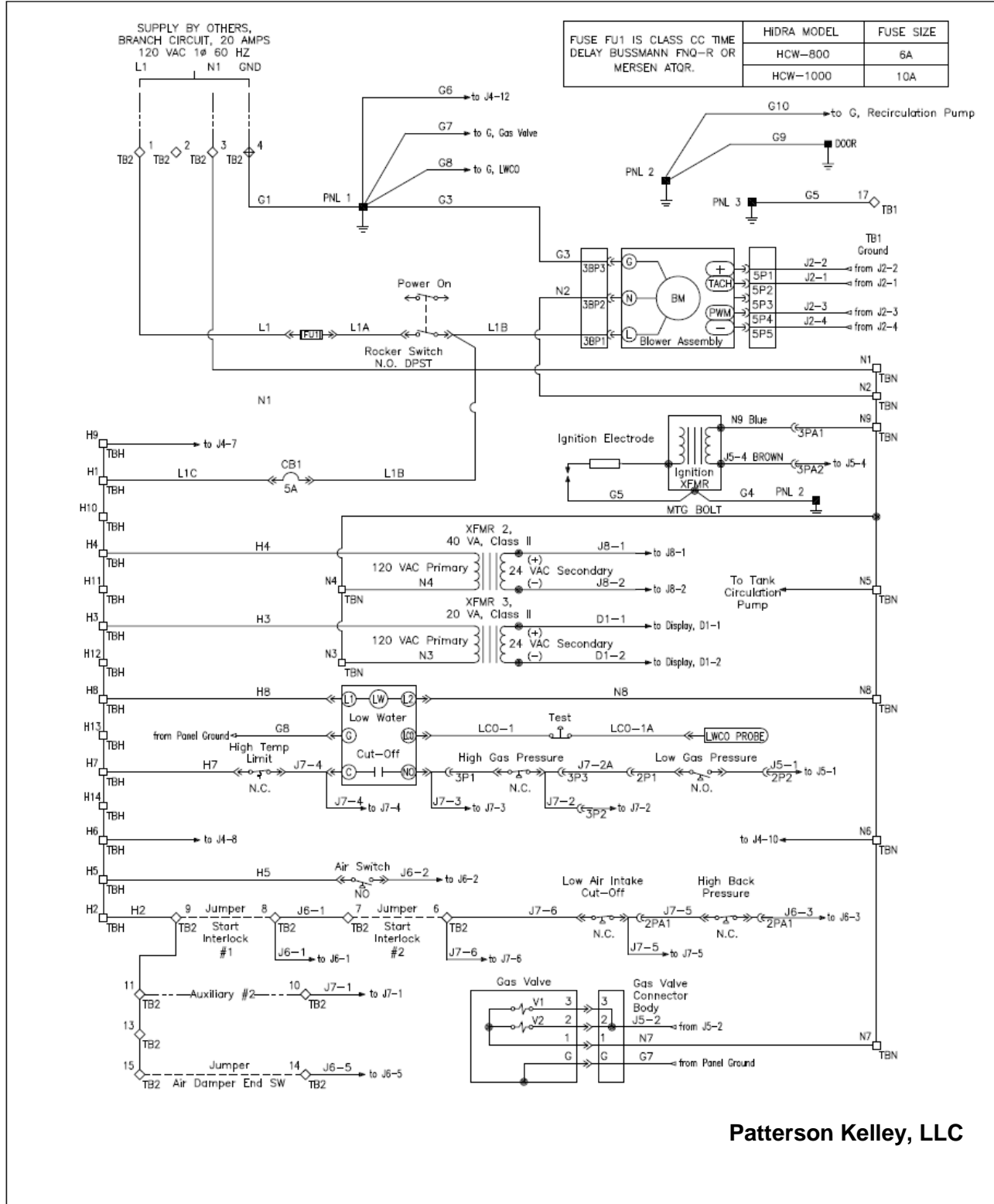

### 3.3.6 Wiring Diagram



Patterson Kelley, LLC

IF ANY OF THE ORIGINAL WIRE SUPPLIED WITH THIS BOILER MUST BE REPLACED, IT MUST BE REPLACED WITH THE SAME UL WIRE TYPE.

HCW 800-1000 / 120 VOLT  
NURO® CONTROL

2682000010 (1)  
REV. C

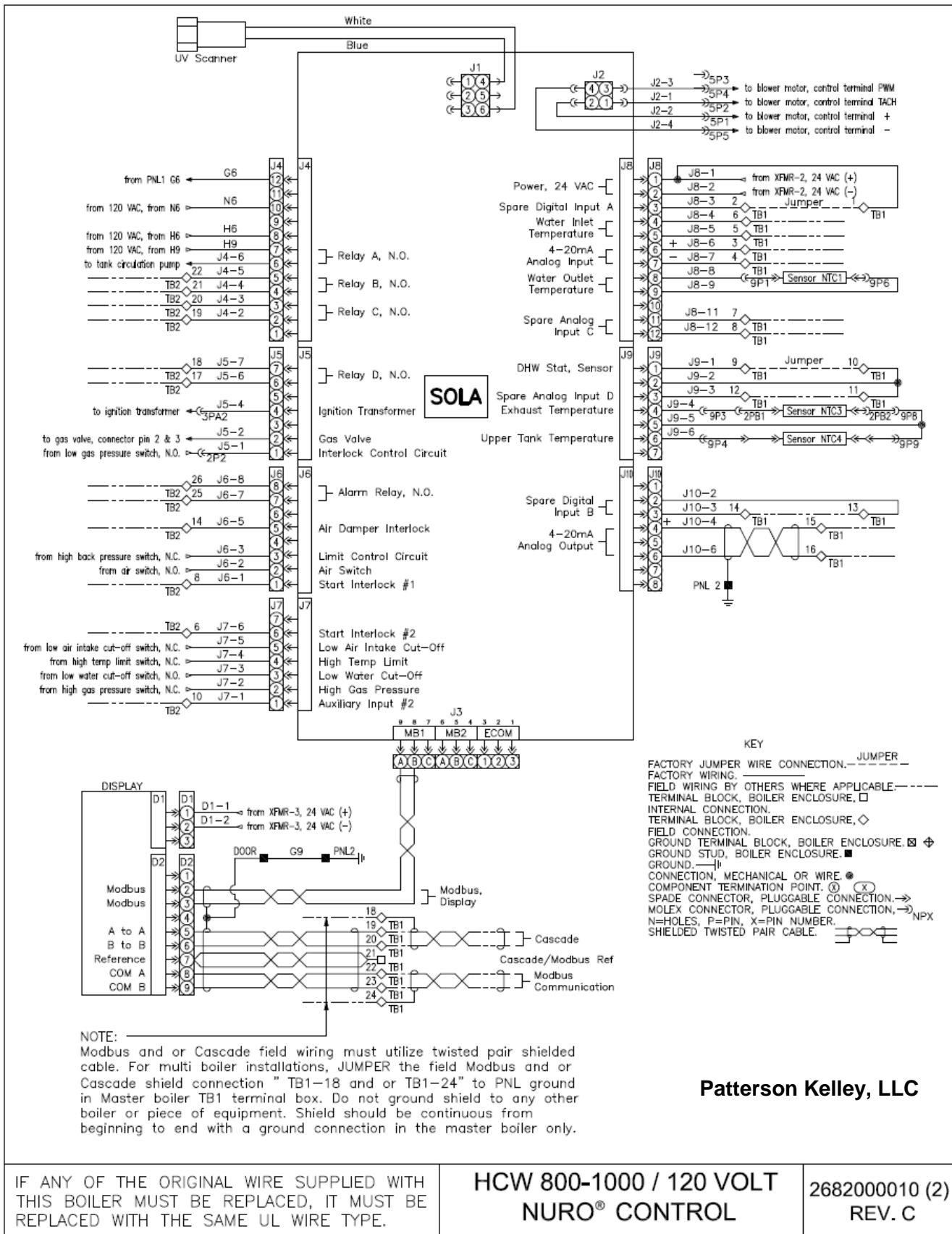

IF ANY OF THE ORIGINAL WIRE SUPPLIED WITH THIS BOILER MUST BE REPLACED, IT MUST BE REPLACED WITH THE SAME UL WIRE TYPE.

HCW 800-1000 / 120 VOLT  
 NURO® CONTROL

2682000010 (2)  
 REV. C