

SUPPLY BY OTHERS,
BRANCH CIRCUIT, 10 AMPS
120 VAC 1Ø 60 HZ

FUSES ARE BUSSMAN FNQ-R CLASS CC ONLY	
FUSE NAME	FUSE SIZE
FU1	10 AMP

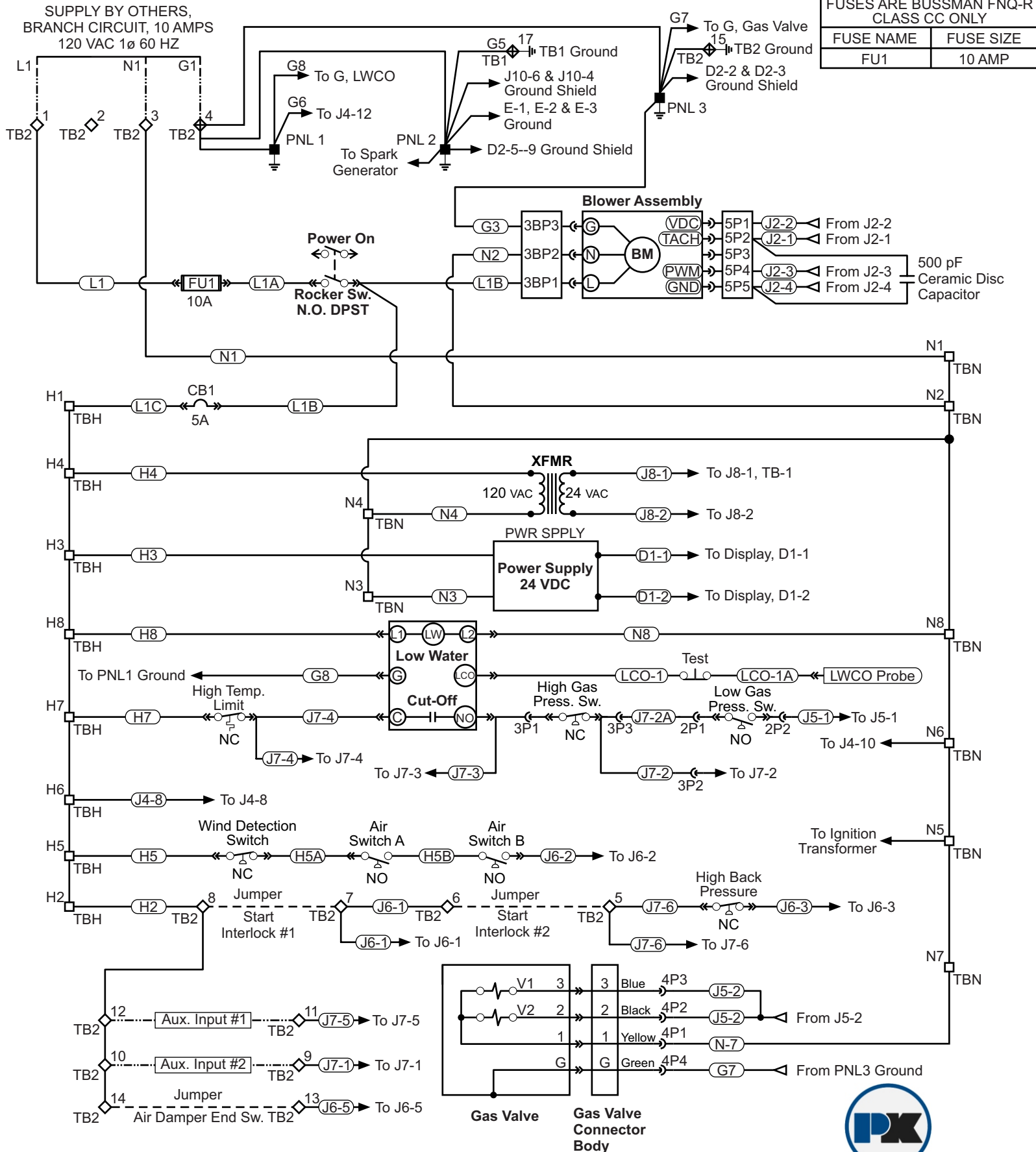

Patterson-Kelley, LLC
East Stroudsburg, PA 18301
570-476-7261
www.pattersonkelley.com

IF ANY OF THE ORIGINAL WIRE SUPPLIED WITH THIS BOILER MUST BE REPLACED, IT MUST BE REPLACED WITH THE SAME UL WIRE TYPE.

**SOLIS 725/850 120V
WITH NURO® CONTROL**

**550201626
REV. 02**

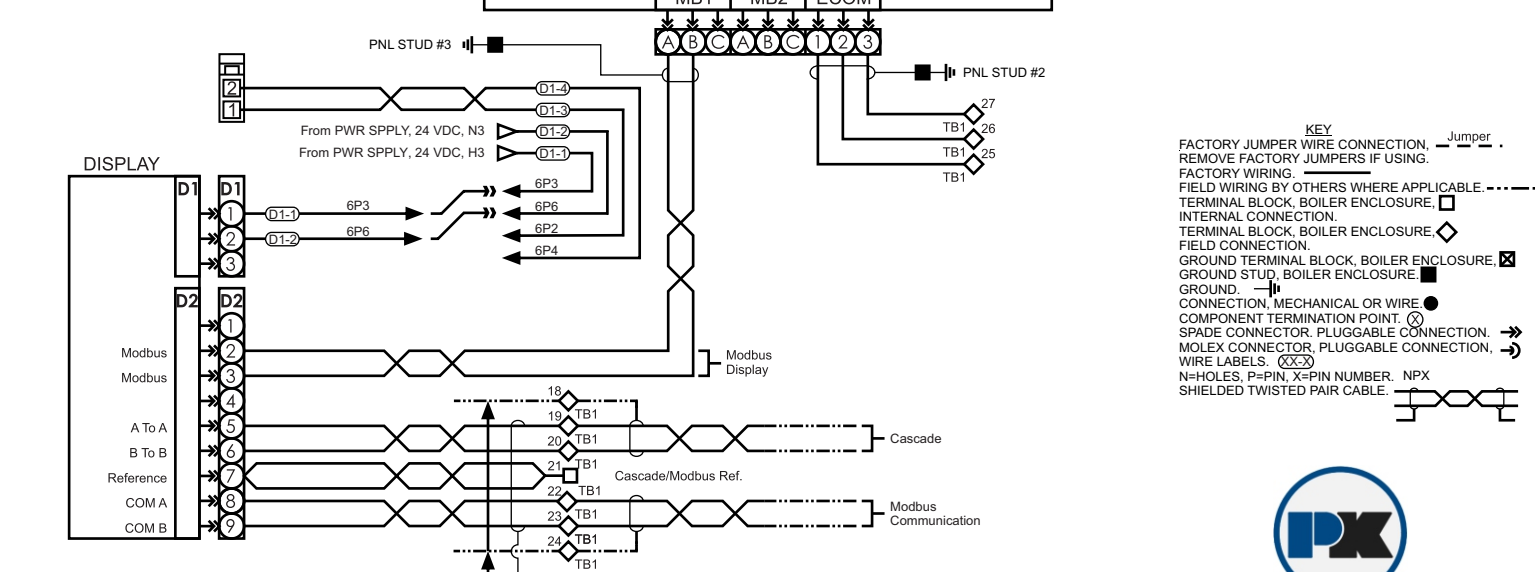
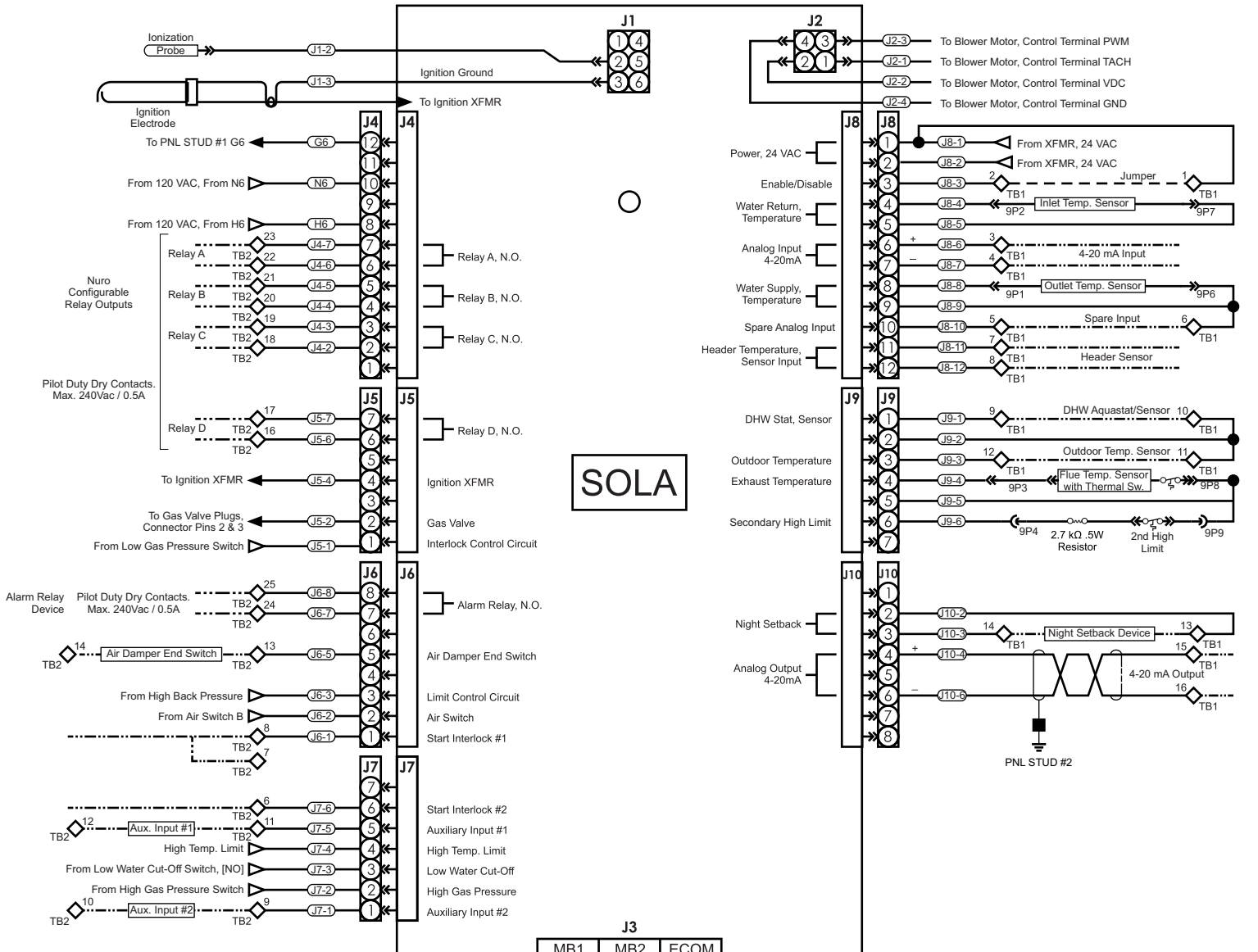

KEY

FACTORY JUMPER WIRE CONNECTION, Jumper

REMOVE FACTORY JUMPERS IF USING.

FACTORY WIRING. -----

FIELD WIRING BY OTHERS WHERE APPLICABLE. -----

TERMINAL BLOCK, BOILER ENCLOSURE. □

INTERNAL CONNECTION. □

TERMINAL BLOCK, BOILER ENCLOSURE. ◇

FIELD CONNECTION. ◇

GROUND TERMINAL BLOCK, BOILER ENCLOSURE. ⊠

GROUND STUD, BOILER ENCLOSURE. ■

GROUND. —|—

CONNECTION, MECHANICAL OR WIRE. ●

COMPONENT TERMINATION POINT. (X)

SPADE CONNECTOR, PLUGGABLE CONNECTION. →

MOLEX CONNECTOR, PLUGGABLE CONNECTION. →

WIRE LABELS. (XXX)

N=HOLES, P=PIN, X=PIN NUMBER, NPX

SHIELDED TWISTED PAIR CABLE. —|—|—|—



Patterson-Kelley, LLC
 East Stroudsburg, PA 18301
 570-476-7261
 www.pattersonkelley.com

IF ANY OF THE ORIGINAL WIRE SUPPLIED WITH THIS BOILER MUST BE REPLACED, IT MUST BE REPLACED WITH THE SAME UL WIRE TYPE.

SOLIS 725/850 120V WITH NURO® CONTROL

550201625 REV. 02