

P-K STORM® Outdoor



Model STW-650, STW-800, & STW-1000
Natural Gas and Liquid Propane with NURO® Control

Rep Name: _____

Email: _____

Phone Number: _____

Date: _____ / _____ / _____

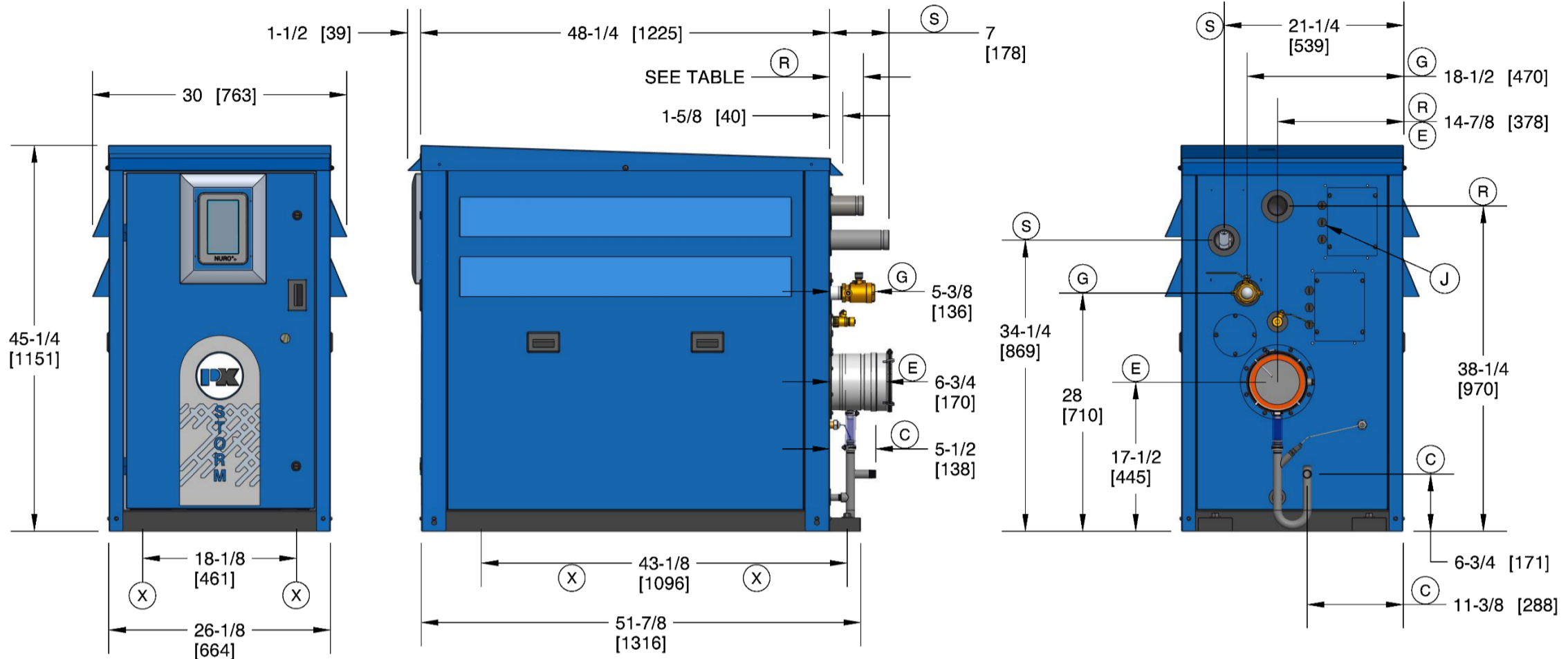

This boiler requires Category IV venting (condensing-positive pressure) or Category II venting[†] (condensing -negative pressure) as defined in ANSI Z223.1/NFPA 54/CSA-B.149 latest edition.

[†]Category II venting must include the optional combustion air damper

BOILER CONNECTIONS		
A	Combustion Air Inlet	6" dia. stub
C	Condensate Drain	3/4" NPT
E	Exhaust Vent	6" PVC/CPVC Pipe Size
G	Natural Gas	1-1/4" NPT-F
J	Wiring Junction Boxes	back panel, internal
P	Pressure Relief Valve	see list for options
R	Boiler Return, Victaulic® clamp	2" pipe, grooved
S	Boiler Supply, Victaulic clamp	2" pipe, grooved
X	Anchor Bolt Locations	(4) 3/4" dia holes

BOILER CONTROLS	
ASME CSD-1 is standard	
Complies with: GE GAP (IRI) guidelines GAP.4.1.0 and GAP.4.1.3	
FM Global 6-4 Section 1.0	
Main Gas Train with Dual Shut-off	
Integrated Boiler Control, NURO Series	
Operating Thermostat, 70°-195°F (38°-92°C)	
High Limit Thermostat, Manual Reset, 100°-197°F (38°-92°C)	
High Exhaust Back Pressure Switch	
LWCO, Probe Type, Manual Reset	
Combustion Air Proving Switch, Differential Pressure Type	
Combustion Blower, Variable Speed, 460 Watt	
Condensate Blockage, Cut-Off Probe	
Flow Switch, Paddle Type	

A.S.M.E. SECTION IV DESIGN DATA	ST-650	ST-800	ST-1000
Max Pressure	160 PSIG		
Max Allowable Temperature	210°F		
Max Setpoint	194°F		
Heated Wet Surface Area	47.25 sq. ft.	55.12 sq. ft.	68.24 sq. ft.
Flow Rate @ 20°FΔT (GPM)	62.4	76.8	96.0
Minimum Flow Rate @ High Fire (GPM) (60°FΔT)	20.8	25.6	32.0
Minimum Flow Rate @ Ignition (GPM) (20°FΔT)	NG: 24.0	NG: 29.5	NG: 36.9
	LP: 29.7	LP: 32.0	LP: 40.3

MODEL SELECTION			
Boilers	<input type="checkbox"/> STW-650	<input type="checkbox"/> STW-800	<input type="checkbox"/> STW-1000
Fuel Options	<input type="checkbox"/> Natural Gas		<input type="checkbox"/> Liquid Propane
Min Inlet Gas Pressure	3.5" w.c. (NG)		5" w.c. (LP)
Max Inlet Gas Pressure	14.0" w.c.		
Max Input (BTU/hr)	650,000	800,000	1,000,000
Max Output (BTU/hr)	624,000	768,000	960,000
Boiler HP	19.4	23.9	29.9
Min Input (BTU/hr)	65,000	80,000	100,000
Min Output (BTU/hr)	62,400	76,800	96,000
Turndown Ratio (NG)	10:1		
Turndown Ratio (LP)	5:1		
Operating Weight	625 lbs	660 lbs	705 lbs
Shipping Weight	648 lbs	675 lbs	707 lbs
Boiler Water Content	5.6 gal	6.6 gal	8.1 gal
Shipping Dimensions	60"x30"x45.25" (LxWxH)		
Power Supply	120V 1ph 60Hz		
Operating Current	< 10 Amps		
Recommended Minimum Circuit Capacity	10 Amps		

PRESSURE RELIEF VALVE/PRESSURE-TEMPERATURE GAUGE			
Shipped Loose for Field Installation			
<input type="checkbox"/>	30 PSIG 1"x 1"	0-100 psi/30-240°F	BP00000400
<input type="checkbox"/>	50 PSIG 1"x 1-1/4"	0-100 psi/30-240°F	BP00000406
<input type="checkbox"/>	60 PSIG 1"x 1"	0-100 psi/30-240°F	BP00000415
<input type="checkbox"/>	75 PSIG 1"x 1"	0-240 psi/30-240°F	BP00000420
<input type="checkbox"/>	80 PSIG 1"x 1"	0-240 psi/30-240°F	BP00000424
<input type="checkbox"/>	100 PSIG 1"x 1-1/4"	0-240 psi/30-240°F	BP00000431
<input type="checkbox"/>	125 PSIG 1"x 1"	0-240 psi/30-240°F	BP00000436
<input type="checkbox"/>	150 PSIG 1"x 1"	0-240 psi/30-240°F	BP00000438

RECOMMENDED CLEARANCE FOR SERVICE ACCESS			
Front - 24"	Top - 24"	Left Side - 24"	Right Side - 24"
Rear - 24"			

Notes:

- Victaulic is a registered trademark of Victaulic Company, Easton PA, USA

- Patterson-Kelley reserves the right to make changes at any time without notification